



National Motor Freight Classification®

Supplement 2 to NMF 100-AW
(Supplements 1 and 2 contain all changes)

Issued: July 6, 2023
Effective: August 5, 2023
(Except as otherwise provided herein)
Expires: January 27, 2024

Issued by:
Erin N. Topper, Issuing Officer
National Motor Freight Traffic Association, Inc., Agent
1001 North Fairfax Street, Suite 600, Alexandria, VA 22314
www.nmfta.org
703.838.1810

For subscription information, call NMFTA Customer Service at 1.866.411.NMFC (6632).

©2023 National Motor Freight Traffic Association, Inc.
All rights reserved. No part of this publication may be used or reproduced in any manner whatsoever without the written permission of National Motor Freight Traffic Association, Inc.

Carriers and other transportation companies who use or refer to any provisions of the National Motor Freight Classification® are required to be bona fide participants in the Classification.

TABLE OF CONTENTS

SUBJECT	PAGE(S)
Participating Member Interstate Carriers	1
Participating Member Intrastate Carriers	1
Participating Freight Forwarder Licensees.....	1
Participating Broker Licensees	1
Cumulative List of Items and Numbered Packages in Supplements.....	2-6
Index to Articles	7-14
Rules.....	15-30
Classification of Articles	31-48
Specifications for Numbered Packages	49-54
Procedures Governing the Investigation and Disposition of Freight Claims For Loss or Damage.....	55-56
Definition of a Delivery Receipt.....	57
Explanation of Abbreviations and Reference Marks	58

Issued by

Erin N. Topper

Issuing Officer

**National Motor Freight Traffic Association, Inc., Agent
1001 North Fairfax Street, Suite 600
Alexandria, Virginia 22314**

Telephone — 703.838.1810

Fax — 703.683.1094

Email — fcdc@nmfta.org

Website — www.nmfta.org

PARTICIPATING MEMBER INTERSTATE CARRIERS

The following NMFTA member carriers are participants in or licensed to participate in this Classification for interstate, intrastate and foreign commerce under authority of powers of attorney issued to National Motor Freight Traffic Association, Inc., Agent or licenses issued by the National Motor Freight Traffic Association, Inc. The provisions of this Classification are limited to intrastate application within the states where the carrier is authorized to operate.

SCAC	CARRIER NAME and DOMICILE	U.S. DOT Number	MC Number
⓪BDRT	B-D-R Transport Inc., Westminster, VT.....	86317	134806
⊕★EZFI	EZ Freight Service LLC, Hatboro, PA.....	3981171	1490672
JJKQ	▶JJT Logistics Inc., Pomona, CA.....	2918976	984454
LTPS	▶Longistics, Park Communications LLC d/b/a, Raleigh, NC.....	2781861	1337144
⊕★MFGN	Mainfreight, Inc., Carson, CA.....	1538326	572473
⓪SKYT	Skyline Transportation, Inc., Knoxville, TN.....	41190	99208

PARTICIPATING MEMBER INTRASTATE CARRIERS

The following NMFTA member carriers are participants in or licensed to participate in this Classification for intrastate commerce under authority of powers of attorney issued to National Motor Freight Traffic Association, Inc., Agent or licenses issued by the National Motor Freight Traffic Association, Inc. The provisions of this Classification are limited to intrastate application within the states where the carrier is authorized to operate.

SCAC	CARRIER NAME and DOMICILE	U.S. DOT Number
⊕★RMFR	Rogue Motor Freight, Inc., Kent, WA.....	582225

PARTICIPATING FREIGHT FORWARDER LICENSEES

The following freight forwarders are licensed to participate in this Classification under authority of powers of attorney issued to National Motor Freight Traffic Association, Inc., Agent or licenses issued by the National Motor Freight Traffic Association, Inc.

SCAC	CARRIER NAME and DOMICILE	U.S. DOT Number	FF Number
⊕★MMCV	MountainMovers Transportation & Logistics LP, Grapevine, TX.....	2233849	FF49906

PARTICIPATING BROKER LICENSEES

The following interstate brokers are licensed to participate in this Classification under authority of powers of attorney issued to National Motor Freight Traffic Association, Inc., Agent or licenses issued by the National Motor Freight Traffic Association, Inc. The participation of each broker named herein is limited, on interstate, intrastate and foreign commerce, to provisions of this Classification applying on the articles and commodities for which the broker is authorized to arrange transportation.

SCAC	BROKER NAME and DOMICILE	U.S. DOT Number	MC or FF Number
⊕★MWYT	Midway Logistics LLC, Wichita, KS.....	3220449	1007751
⊕★PEND	Weizhen Supply Chain LLC DBA Weizhen Freight & Logistics Company, Dallas, TX.....	4064993	1528841

CUMULATIVE LIST OF ITEMS AND NUMBERED PACKAGES IN SUPPLEMENTS

Listed below are items and numbered packages that have been added, amended or brought forward in this supplement and previous supplements.

ITEM	SUP	ITEM	SUP	ITEM	SUP	ITEM	SUP	ITEM	SUP	ITEM	SUP
180-A	2	15620-A	2	17200-A	2	26610-A	1	33720-A	1	39352-A	1
181-A	2	15640-A	2	17201-A	2	26800-A	1	34095-A	1	39370-A	1
183-B	2	15680-A	2	17260-A	2	★26820	1	34100-A	1	39372-A	1
245-A	1	15820-A	2	17290-A	2	★26821	1	34102-A	1	39390-A	1
680-A	1	15930-A	2	17300-A	2	26840-A	1	34140-A	1	39400-A	1
685-A	1	15940-A	2	17301-A	2	26860-A	1	34282-A	2	★39495	1
4605-A	2	16040-A	2	17310-A	2	26865-A	1	35085-A	2	★39496	1
4615-A	2	16060-A	2	17330-A	2	26867-A	1	35086-A	2	★39497	1
4620-A	2	16080-A	2	17335-A	2	26880-A	1	35087-A	2	40215-A	2
4621-A	2	16100-A	2	17340-A	2	28715-A	1	35255-A	2	40217-A	2
4622-A	2	16160-A	2	17370-A	2	30160-A	1	★35256	2	40220-A	2
★4625	2	16190-A	2	17460-A	2	30260-A	1	35385-A	1	40222-A	2
★4626	2	16192-A	2	17462-A	2	30261-A	1	35386-A	1	★40225	2
4630-A	2	16200-A	2	17465-A	2	30263-A	1	35932-A	2	★40226	2
4631-A	2	16255-A	2	17470-A	2	30320-A	1	36180-A	2	40230-A	2
4632-A	2	16260-A	2	17540-A	2	30322-A	1	36190-A	2	40235-A	2
4633-A	2	16270-A	2	17560-A	2	30323-A	1	36192-A	2	40236-A	2
4635-A	2	16280-A	2	17561-A	2	30390-A	1	36210-A	2	40240-A	2
4637-A	2	16281-A	2	17600-A	2	32530-A	1	36212-A	2	40242-A	2
4740-A	1	16320-A	2	17601-A	2	32770-A	1	36220-A	2	40245-A	2
4742-A	1	16330-A	2	17660-A	2	★32800	1	36410-A	2	40247-A	2
12930-A	1	16332-A	2	17662-A	2	★32801	1	36411-A	2	40255-A	2
13120-A	1	16420-A	2	17685-A	2	32810-A	1	36450-A	2	40265-A	2
13121-A	1	16430-A	2	17686-A	2	32890-A	1	36650-A	1	40290-A	2
13260-A	1	16440-A	2	17687-A	2	32970-A	1	★36651	1	40300-A	2
13261-A	1	16490-A	2	17688-A	2	32990-A	1	★37020	2	40304-A	2
13263-A	1	16520-A	2	17689-A	2	33010-A	1	★37021	2	40305-A	2
13320-A	1	16530-A	2	17690-A	2	33050-A	1	39200-A	1	40307-A	2
13321-A	1	16550-A	2	17691-A	2	33055-A	1	39210-A	1	40310-A	2
13322-A	1	16620-A	2	17692-A	2	33060-A	1	39230-A	1	40320-A	2
13360-A	1	16630-A	2	17693-A	2	33070-A	1	39232-A	1	40330-A	2
15505-A	2	16650-A	2	17694-A	2	33075-A	1	39235-A	1	40350-A	2
15520-A	2	16660-A	2	17695-A	2	33090-A	1	39237-A	1	40360-A	2
15522-A	2	16810-A	2	17697-A	2	33100-A	1	39238-A	1	40370-A	2
15523-A	2	16820-A	2	17698-A	2	33163-A	1	39240-A	1	40372-A	2
15524-A	2	16835-A	2	17740-A	2	33180-A	1	39245-A	1	40375-A	2
15525-A	2	16836-A	2	18460-A	2	33182-A	1	39247-A	1	40390-A	2
★15526	2	16950-A	2	18462-A	2	33200-A	1	39250-A	1	40570-A	2
★15527	2	16985-A	2	20020-A	1	33210-A	1	39270-A	1	42445-A	2
★15528	2	17040-A	2	20021-A	1	33220-A	1	39272-A	1	42446-A	2
15530-A	2	17050-A	2	20022-A	1	33225-A	1	39280-A	1	42450-A	2
15535-A	2	17051-A	2	23700-A	2	33240-A	1	39281-A	1	42451-A	2
15540-A	2	17056-A	2	23701-A	2	33260-A	1	39300-A	1	43940-A	1
15545-A	2	17060-A	2	★23702	2	33270-A	1	39315-A	1	★43941	1
15560-A	2	17100-A	2	★23703	2	33280-A	1	39320-A	1	43942-A	1
15562-A	2	17101-A	2	23840-A	1	33430-A	2	39330-A	1	48110-A	1
15580-A	2	17110-A	2	24415-A	1	33431-A	2	39342-A	1	49280-A	2
15590-A	2	17160-A	2	25320-A	1	33440-A	2	39345-A	1	49880-A	1
15600-A	2	17162-A	2	25328-A	1	33442-A	2	39350-A	1	49881-A	1

CUMULATIVE LIST OF ITEMS AND NUMBERED PACKAGES IN SUPPLEMENTS

Listed below are items and numbered packages that have been added, amended or brought forward in this supplement and previous supplements.

ITEM	SUP	ITEM	SUP	ITEM	SUP	ITEM	SUP	ITEM	SUP	ITEM	SUP
49885-A	1	52880-A	2	56760-A	1	59040-A	2	68550-A	2	79070-A	1
49886-A	1	52881-A	2	56765-A	1	59050-A	2	68560-A	2	79080-A	1
49983-A	1	★52882	2	56770-A	1	59230-A	2	68580-A	2	79110-A	2
49984-A	1	52904-A	2	56775-A	1	59270-A	2	68600-A	2	79132-A	2
49996-A	1	52910-A	2	56785-A	1	★59413	2	68620-A	2	79134-A	2
49997-A	1	52920-A	2	56786-A	1	59415-A	2	72738-A	1	79135-A	2
50333-A	1	52940-A	2	56787-A	1	61535-A	1	72739-A	1	79150-A	1
★51015	1	52950-A	2	56788-A	1	62220-A	1	72740-A	1	79170-A	1
51020-A	1	52960-A	2	56789-A	1	62515-A	2	72745-A	1	79180-A	1
51021-A	1	52980-A	2	56795-A	1	63160-A	1	72750-A	1	79190-A	1
51022-A	1	52990-A	2	56820-A	1	63161-A	1	72760-A	1	79200-A	1
51023-A	1	53025-A	1	56828-A	1	63162-A	1	72762-A	1	79201-A	1
51024-A	1	53026-A	1	★56830	1	63163-A	1	72795-A	1	79202-A	1
51025-A	1	56060-A	2	56833-A	1	63420-A	2	72800-A	1	79255-A	1
51026-A	1	56290-A	1	56835-A	1	63423-A	2	72802-A	1	79275-A	1
51027-A	1	56291-A	1	56837-A	1	63424-A	2	73150-B	2	79277-A	1
51028-A	1	56292-A	1	56840-A	2	63595-A	2	73151-B	2	79278-A	1
51120-A	1	56294-A	1	56841-A	2	65215-A	1	73260-B	2	★79300	1
51220-A	1	56295-A	1	56860-A	1	65220-A	1	73261-B	2	★79301	1
51280-A	1	56400-A	1	56880-A	1	65250-A	1	73262-A	2	★79302	1
51290-A	1	56401-A	1	56890-A	1	65254-A	1	★73263	2	★79303	1
51292-A	1	56440-A	1	56910-A	1	★65300	1	73360-A	2	★79304	1
51294-A	1	56445-A	1	56911-A	1	65320-A	1	73362-A	2	★79305	1
51320-A	1	56533-A	1	56920-A	1	65340-A	1	73370-A	1	79380-A	1
51410-A	1	56534-A	1	★56930	1	65740-A	2	73570-A	2	79400-A	1
51420-A	1	56536-A	1	★56931	1	65930-A	2	74445-A	1	79402-A	1
51432-A	1	56540-A	1	★56932	1	66500-A	1	74450-A	1	79460-A	1
51450-A	1	56550-A	1	56940-A	1	68200-A	2	74451-A	1	79463-A	1
51540-A	1	56551-A	1	56950-A	1	68210-A	2	74455-A	1	79464-A	1
51550-A	1	56555-A	1	56960-A	1	68240-A	2	74490-A	2	79465-A	1
51560-A	1	56557-A	1	56970-A	1	68260-A	2	74491-A	2	79466-A	1
51900-A	1	56560-A	1	56980-A	1	68280-A	2	74495-A	1	79467-A	1
51901-A	1	56562-A	1	57010-A	1	68290-A	2	74780-A	1	79468-A	1
51902-A	1	★56570	1	57011-A	1	68300-A	2	74900-A	1	79480-A	1
51920-A	1	★56590	1	57020-A	1	68310-A	2	74910-A	1	79520-A	1
52110-A	1	★56591	1	57060-A	1	68311-A	2	74940-A	1	79522-A	1
52130-A	1	56600-A	1	57075-A	1	68320-A	2	74960-A	1	79600-A	1
52132-A	1	56620-A	1	57170-A	2	68340-A	2	74970-A	1	79602-A	1
52135-A	1	56630-A	1	58400-A	2	68360-A	2	74990-A	1	79620-A	1
52175-A	1	56640-A	1	58420-A	2	68380-A	2	75010-A	1	79640-A	1
52185-A	1	56660-A	1	58422-A	2	68400-A	2	75030-A	1	79644-A	1
52190-A	1	56670-A	1	58560-A	2	68405-A	1	75050-A	1	79660-A	1
★52200	1	56680-A	1	58692-A	2	68420-A	2	★78400	1	79700-A	1
★52201	1	56682-A	1	58770-A	2	68430-A	2	79000-A	1	79705-A	1
52250-A	1	56695-A	1	58771-A	2	68440-A	2	79022-A	1	79800-A	1
52252-A	1	56705-A	1	58772-A	2	68460-A	2	79023-A	1	79810-A	1
52254-A	1	56720-A	1	58773-A	2	68500-A	2	79024-A	1	79840-A	1
52860-A	2	56740-A	1	★58774	2	68520-A	2	79026-A	1	79860-A	1
52870-A	2	56750-A	1	58920-A	2	68540-A	2	79050-A	1	79880-A	1

CUMULATIVE LIST OF ITEMS AND NUMBERED PACKAGES IN SUPPLEMENTS

Listed below are items and numbered packages that have been added, amended or brought forward in this supplement and previous supplements.

ITEM	SUP	ITEM	SUP	ITEM	SUP	ITEM	SUP	ITEM	SUP	ITEM	SUP
79890-A	1	80832-A	1	81650-A	1	82320-A	1	83230-A	1	84364-B	2
79891-A	1	80865-A	1	81651-A	1	82380-A	1	83233-A	1	84410-A	2
79900-A	1	80866-A	1	81660-A	1	82400-A	1	83240-A	1	84451-A	2
79940-A	1	80868-A	1	81725-A	1	82410-A	1	83250-A	1	84452-A	2
79960-A	1	80869-A	1	81740-A	1	82415-A	1	83252-A	1	84470-A	2
79970-A	1	80900-A	1	81741-A	1	82416-A	1	83270-A	1	84510-A	2
79980-A	1	80904-A	1	81750-A	1	82418-A	1	83310-A	1	84570-A	2
80000-A	1	80920-A	1	81751-A	1	82420-A	1	83330-A	1	84600-A	2
80020-A	1	80930-A	1	81752-A	1	82440-A	1	83370-A	1	84690-A	2
80022-A	1	80950-A	1	81755-A	1	82560-A	1	83410-A	1	84700-A	2
80040-A	1	80960-A	1	81756-A	1	82600-A	1	83430-A	1	84702-A	2
80060-A	1	81100-A	1	81760-A	1	82620-A	1	83450-A	1	84703-A	2
80070-A	1	81110-A	1	81780-A	1	82630-A	1	83470-A	1	84705-A	2
80080-A	1	81111-A	1	81800-A	1	82640-A	1	83490-A	1	84706-A	2
80082-A	1	81150-A	1	81820-A	1	82641-A	1	83495-A	1	84710-A	2
80100-A	1	81170-A	1	81900-A	1	82642-A	1	83510-A	1	84711-A	2
80120-A	1	81270-A	1	81920-A	1	82643-A	1	83550-A	1	84720-A	2
80121-A	1	81271-A	1	81925-A	1	82670-A	1	83620-A	1	84722-A	2
80200-A	1	81272-A	1	81930-A	1	82750-A	1	83622-A	1	84730-A	2
80220-A	1	81300-A	1	81931-A	1	82751-A	1	83630-A	1	84732-A	2
80240-A	1	81310-A	1	81940-A	1	82754-A	1	83640-A	1	84750-A	2
80320-A	1	81311-A	1	81960-A	1	82755-A	1	83642-A	1	84770-A	2
80360-A	1	81320-A	1	81970-A	1	82760-A	1	83985-A	2	84790-A	2
80400-A	1	81330-A	1	81990-A	1	82762-A	1	83990-A	2	84792-A	2
80440-A	1	81332-A	1	82030-A	1	82770-A	1	84000-A	2	84810-A	2
80441-A	1	81340-A	1	82031-A	1	82775-A	1	84020-A	2	84830-A	1
80442-A	1	81350-A	1	82050-A	1	82790-A	1	84040-A	2	84960-A	2
80443-A	1	81360-A	1	82100-A	1	82820-A	1	84080-A	2	84980-A	2
80444-A	1	81372-A	1	82101-A	1	82825-A	1	84100-A	2	86070-A	1
80445-A	1	81373-A	1	82102-A	1	82830-A	1	84140-A	2	88480-A	1
80446-A	1	81380-A	1	82103-A	1	82840-A	1	84170-A	2	89000-A	2
80480-A	1	81390-A	1	82150-A	1	82842-A	1	84172-A	2	89012-A	2
80485-A	1	81394-A	1	82155-A	1	82870-A	1	84175-A	2	89030-A	2
80486-A	1	81395-A	1	82156-A	1	82871-A	1	84176-A	2	89050-A	2
80500-A	1	★81396	1	82160-A	1	82930-A	1	84260-B	2	89070-A	2
80520-A	1	81430-A	1	82163-A	1	82950-A	1	84261-B	2	89100-A	2
80521-A	1	81440-A	1	82164-A	1	82970-A	1	84262-B	2	89130-A	2
80522-A	1	81460-A	1	82170-A	1	82990-A	1	★84263	2	89150-A	2
80540-A	1	81462-A	1	82210-A	1	83020-A	1	★84264	2	89170-A	2
80542-A	1	81463-A	1	82220-A	1	83060-A	1	★84265	2	89190-A	2
80564-A	1	81465-A	1	82230-A	1	83080-A	1	84270-A	2	89210-A	2
80580-A	1	81467-A	1	82250-A	1	83090-A	1	84271-A	2	★89230	2
80581-A	1	81560-A	1	82251-A	1	83095-A	1	84300-A	2	★89231	2
80582-A	1	81565-A	1	82270-A	1	83100-A	1	84302-A	2	89610-A	2
80583-A	1	81570-A	1	82271-A	1	83140-A	1	84303-A	2	89670-A	2
80584-A	1	81590-A	1	82272-A	1	83160-A	1	84304-A	2	89770-A	2
80635-A	1	81630-A	1	82273-A	1	83170-A	1	84340-A	2	89935-A	2
80730-A	1	81635-A	1	82280-A	1	83190-A	1	84360-A	2	89937-A	2
80830-A	1	81637-A	1	82300-A	1	83210-A	1	84362-B	2	91100-A	2

CUMULATIVE LIST OF ITEMS AND NUMBERED PACKAGES IN SUPPLEMENTS

Listed below are items and numbered packages that have been added, amended or brought forward in this supplement and previous supplements.

ITEM	SUP	ITEM	SUP	ITEM	SUP	ITEM	SUP	ITEM	SUP	ITEM	SUP
91180-A	2	131674-A	2	150345-A	2	151152-A	2	155050-A	1	156910-A	1
91260-A	2	133300-A	1	150370-A	2	151170-A	2	155051-A	1	156911-A	1
91262-A	2	136500-A	1	150380-A	2	151190-A	2	155052-A	1	156912-A	1
91300-A	2	136512-A	1	150390-A	2	151192-A	2	155053-A	1	156920-A	1
91320-A	2	136514-A	1	150391-A	2	151210-A	2	155054-A	1	156950-A	1
91340-A	1	136516-A	1	150392-A	2	151230-A	2	★155055	1	156960-A	1
91360-A	2	137380-A	1	★150400	2	151240-A	2	156500-A	1	157020-A	1
91380-A	2	137385-A	1	150430-A	2	151250-A	2	156502-A	1	157060-A	1
91420-A	2	★137390	1	150433-A	2	151270-A	2	156600-B	2	157130-A	1
91460-A	2	★137391	1	150435-A	2	151280-A	2	156601-A	2	157160-A	1
91500-A	2	137400-A	1	★150550	2	151290-A	2	156602-B	2	157170-A	1
91520-A	1	137420-A	1	★150551	2	151300-A	2	156603-B	2	157172-A	1
91540-A	2	137440-A	1	150600-A	2	151301-A	2	156604-B	2	157190-A	1
91560-A	2	137452-A	1	150620-A	2	151315-A	2	156620-A	1	157192-A	1
91580-A	1	137456-A	1	150650-A	2	151317-A	2	156630-A	1	157205-A	1
91600-A	2	141900-A	1	150652-A	2	151318-A	2	156640-A	1	157215-A	1
★91650	2	142000-A	2	150654-A	2	151320-A	2	156642-A	1	157230-A	1
★91651	2	142050-A	2	150670-A	2	151370-A	2	156643-A	1	157231-A	1
95980-A	1	142052-A	2	150672-A	2	151390-A	2	156644-A	1	157234-A	1
103300-A	1	142060-A	2	150674-A	2	151392-A	2	156645-A	1	157242-A	1
103301-A	1	142085-A	2	150690-A	2	151393-A	2	156647-A	1	157243-A	1
109700-A	1	142230-A	2	150700-A	2	151395-A	2	156648-A	1	157250-A	1
109701-A	1	142400-A	2	150720-A	2	151400-A	2	156649-A	1	157300-A	1
109702-A	1	142420-A	1	150740-A	2	151402-A	2	156650-A	1	157302-A	1
109703-A	1	142440-A	2	150760-A	2	151430-A	1	156652-A	1	157320-A	1
109704-A	1	142460-A	2	150780-A	2	151440-A	2	156660-A	1	157321-A	1
109705-A	1	145350-A	1	150784-A	2	151460-A	2	156661-A	1	157322-A	1
109706-A	1	149020-A	1	150805-A	2	151461-A	2	156680-A	1	157463-A	1
109990-A	2	149021-A	1	150810-A	2	151500-A	2	156690-A	1	160450-A	2
109992-A	2	149022-A	1	150850-A	2	151520-A	2	156700-A	1	★160460	2
110865-A	1	149030-A	1	150890-A	2	151620-A	2	156705-A	1	★160461	2
111120-A	1	149031-A	1	150910-A	2	151630-A	2	156707-A	1	★160462	2
112480-A	2	149080-A	1	150930-A	2	151640-A	2	156730-A	1	162260-A	1
114390-A	1	149200-A	1	150932-A	2	151660-A	2	156731-A	1	162350-A	1
114391-A	1	149220-A	1	150934-A	2	151662-A	2	156732-A	1	162910-A	2
115220-A	1	149225-A	1	150936-A	2	151664-A	2	156740-A	1	162920-A	2
115240-A	1	149230-A	1	150950-A	2	151680-A	2	156750-A	1	★162921	2
118520-A	1	149250-A	1	150970-A	2	151780-A	2	156760-A	1	164390-A	1
121400-A	1	149255-A	1	150971-A	2	151781-A	2	156780-A	1	164393-A	1
121401-A	1	149260-A	1	150990-A	2	151800-A	2	156790-A	1	164394-A	1
★123135	1	149261-A	1	151010-A	2	151820-A	2	156800-A	1	166990-A	1
★123136	1	149263-A	1	151012-A	2	151822-A	2	156820-A	1	171450-A	1
125850-A	2	149265-B	2	151030-A	2	152280-A	1	156830-A	1	173720-A	2
125851-A	2	149266-A	2	151050-A	2	152710-A	1	156831-A	1	174002-A	2
125852-A	2	149269-A	1	151070-A	2	153120-A	2	156832-A	1	174610-A	2
125853-A	2	149270-A	1	151110-A	2	153730-A	2	156834-A	1	174611-A	2
131670-A	2	149271-A	1	151130-A	2	154900-A	1	156845-A	1	174612-A	2
131672-A	2	150300-A	2	151132-A	2	155045-A	1	156860-A	1	174613-A	2
131673-A	2	150310-A	2	151150-A	2	155047-A	1	156870-A	1	174630-A	1

CUMULATIVE LIST OF ITEMS AND NUMBERED PACKAGES IN SUPPLEMENTS

Listed below are items and numbered packages that have been added, amended or brought forward in this supplement and previous supplements.

ITEM	SUP	ITEM	SUP	ITEM	SUP	PACKAGE	SUP	PACKAGE	SUP	PACKAGE	SUP
178080-A	2	181921-A	2	197270-A	1	1350	1	67F	2	134F	2
178090-A	2	186100-A	1	197330-A	1	2174	2	69F	2	135F	2
★178091	2	187120-A	1	197337-A	1	2185	1	72F	2	136F	2
178095-A	2	187645-A	2	197339-A	1	2233	1	77F	2	138F	2
178690-A	1	187682-A	2	197350-A	1	2250	1	79F	2	139F	2
178850-A	2	188560-A	1	197352-A	1	2371	1	80F	2	140F	2
178910-A	2	188561-A	1	197390-A	1	2376	1	85F	2	141F	2
178911-A	2	188950-A	1	197417-A	1	2400	2	86F	2	142F	2
178920-A	2	★189000	1	197440-A	1	2488	2	87F	2	144F	2
178930-A	2	189620-A	1	197460-A	1	2491	2	88F	2	145F	2
178931-A	2	189800-A	1	197462-A	1	2520	1	91F	2	146F	2
178970-A	2	189804-A	1	197465-A	1	6F	2	92F	2	149F	2
178980-A	2	★190270	1	197480-A	1	7F	2	93F	2	150F	2
178990-A	2	★190271	1	197520-A	1	8F	2	95F	2	151F	2
178995-A	2	190290-A	1	197560-A	1	9F	2	97F	2	152F	2
179020-A	2	192270-A	1	197583-A	1	15F	2	98F	2	155F	2
179050-A	2	193600-A	1	197586-A	1	16F	2	101F	2	156F	2
179055-A	2	194380-A	1	197590-A	1	23F	2	106F	2	3000S	2
179057-A	2	194720-A	1	197592-A	1	24F	2	109F	2	3001S	2
179065-A	2	195020-A	1	197593-A	1	31F	2	110F	2	3002S	2
179070-A	2	195250-A	1	197597-A	1	34F	2	111F	2	3003S	2
179072-A	2	195251-A	1	300105-A	2	38F	2	114F	2	3004S	2
179090-A	2	195880-A	1	300115-A	2	39F	2	115F	2	3005S	2
179100-A	2	196300-A	1	300125-A	2	40F	2	117F	2	3006S	2
179120-A	2	196360-A	1	300130-A	2	41F	2	118F	1	3007S	2
179140-A	2	196640-A	2	300135-A	2	43F	2	125F	2	3008S	2
179150-A	2	196840-A	1	300150-A	2	45F	2	126F	2	3009S	2
179160-A	2	196840-A	2	300155-A	2	46F	2	127F	2	3010S	2
179175-A	2	196880-A	2	★500300	2	50F	2	128F	2		
179180-A	2	★197230	1	PACKAGE	SUP	52F	2	129F	2		
179182-A	2	★197231	1	831	1	53F	2	131F	2		
179200-A	2	197240-A	1	942	2	61F	2	132F	2		
181920-A	2	197260-A	1	969	1	64F	2	133F	2		

INDEX TO ARTICLES

Article	Item	Article	Item	Article	Item
A					
Accessories:		ⓑ Barbells	16190	Books: (Cont'd)	
Ⓐ Desk, NOI	179180	ⓒ Barley	89230	ⓑ <i>With paper or paperboard covers, scrap or waste</i>	151390
Adhesive(s):		Bar(s):		Boots:	
ⓑ <i>Electrically conductive, containing gold or silver</i>	4630	ⓑ <i>Cross, track or field house</i>	17691	ⓑ <i>Conductor pipe, cast iron</i>	36220
ⓑ <i>Hot melt, in rolled sheets</i>	4615	ⓑ Baseballs	15600	ⓑ Bowling Balls, NOI, other than hollow molded plastic	15930
ⓒ <i>NOI, not required by DOT to bear a Hazard Class or Hazard Division label or placard</i>	4625	Base(s):		ⓑ Bowling Pins, other than hollow molded plastic	15940
ⓑ <i>Synthetic resin, consisting of paper coated or impregnated with synthetic resin adhesive</i>	4635	ⓑ <i>Baseball</i>	15620	Boxes:	
ⓑ Agenda Books	178910	ⓑ <i>Chewing gum</i>	91260	ⓑ <i>Document, paper, pulpboard or paper or pulpboard and wood</i>	142085
Ⓐ Agenda Books, NOI	179180	ⓑ <i>Softball</i>	15620	ⓑ <i>Invoice, paper, pulpboard or paper or pulpboard and wood</i>	142085
Apparatus:		ⓑ Bases and pens	178970	ⓑ <i>Letter, paper, pulpboard or paper or pulpboard and wood</i>	142085
ⓑ <i>Exercising, tubular metal frame with cloth or fabric body support or sling</i>	15505	ⓑ Basketballs, inflated, official or regulation size and weight	15560	ⓑ <i>Vaulting pole</i>	17689
ⓑ Appointment Books	178910	ⓑ Batons, twirling	15520	Brick(s):	
Ⓐ Appointment Books, NOI	179180	ⓑ Bats, baseball, softball or cricket, other than hollow plastic	15680	ⓑ <i>Pumice stone</i>	162910
Ⓐ Automobile Polish or Wax, not required by DOT to bear a Hazard Class or Hazard Division label or placard	160460	Ⓐ Bats, sports	15520	Briquettes:	
B					
Backboards:		Ⓐ BB Guns	15520	ⓑ <i>Carbon, NOI</i>	40570
ⓑ <i>Basketball</i>	15520	Beverages:		ⓑ <i>Charcoal, coconut shell, nut shell, NOI, or fruit pit, not activated, not required by DOT to bear a Hazard Class or Hazard Division label or placard</i>	42450
Backs:		ⓑ <i>Fruit juice, other than frozen</i>	73260	Broilers:	
ⓑ <i>Calendar</i>	178910	ⓑ <i>Vegetable juice, other than frozen</i>	73260	ⓑ <i>Iron or wire, NOI, flat or nested</i>	52870
Bags:		Binder(s):		ⓑ Buckwheat	89050
Ⓐ <i>Golf</i>	187645	ⓑ <i>Vertical filing</i>	142050	Ⓐ Buffing Compounds, NOI, not required by DOT to bear a Hazard Class or Hazard Division label or placard	160460
ⓑ <i>Golf club</i>	16490	ⓑ Binder-trays, bookkeeping	142460	Butts:	
ⓑ Bait, fish	15535	Binding(s):		ⓑ <i>Target, hay, grass, straw or wood excelsior</i>	17560
Ⓐ Bait, fish, shelf-stable	15520	ⓑ <i>Alpine snow ski, metal or metal and plastic</i>	15820	C	
ⓑ Bakeware, metal, NOI	52880	Ⓐ Blackboards	23700	ⓑ Calendar Backs or Mounts	178910
Ⓐ Bakeware, metal, NOI, other than electric or gas	52880	ⓑ Blackboards, NOI	23700	ⓑ Calendar Desk Pads or Date Pads	178910
Balls:		ⓑ Blackboards, portable, revolving or reversible, on stands	79110	ⓑ Calendars:	
Ⓐ Bowling, NOI	15520	ⓑ Blackboards, Stands and Seats combined, plastic, steel and masonite, KD flat	79132	ⓑ <i>NOI, other than wholly of plastic</i>	178910
ⓑ Bowling, NOI, other than hollow molded plastic	15930	ⓑ Blackboards, Stands and Seats combined, wood or wood and steel, KD flat	79135	ⓑ <i>Wholly of plastic</i>	179180
ⓑ Croquet, composition	15540	ⓑ Blacking, automobile top, carriers', harness, shoe, stove or leather, NOI	58420	ⓑ <i>With thermometers attached</i>	178910
ⓑ Golf	16440	Block(s):		Ⓐ Calendars, NOI	179180
ⓑ Hand, rubber, hollow	15545	ⓑ <i>Eraser stock</i>	178995	ⓑ Cannons:	
ⓑ Inflated, NOI, official or regulation size and weight	15560	ⓑ <i>Kindergarten, solid</i>	84790	ⓑ <i>Life line throwing</i>	40210
ⓑ Ping-pong	15580	ⓑ <i>Pumice stone</i>	162920	ⓑ <i>Muzzle loading</i>	40210
ⓑ Play, NOI, spherical, solid or sponge rubber, not exceeding 3 1/2 inches in diameter	84570	ⓑ <i>School, educational construction, wood, in the white</i>	83990	ⓑ <i>Ordnance</i>	146250
ⓑ Polo, wood	17040	ⓑ <i>Starting, track or field house</i>	17687	ⓑ <i>Toy, steel</i>	84810
ⓑ Shot-putting	17686	ⓑ <i>Toy, corrugated fiberboard, KD flat</i>	84960	Ⓐ Cannons, life line throwing or muzzle loading	40210
ⓑ Soccer, inflated, official or regulation size and weight	15560	ⓑ <i>Toy, nested</i>	84770	Ⓐ Cannons, ordnance	146250
Ⓐ Sports, NOI	15520	ⓑ <i>Toy, solid</i>	84790	Cans:	
ⓑ Squash, rubber, hollow	15545	Ⓐ Blotters, desk	179180	Ⓐ <i>Fuel or flammable liquid storage or dispensing, hand portable</i>	174610
ⓑ Table tennis	15580	Ⓐ Board Games	84260	ⓑ <i>Fuel storage, 20-gauge or thicker sheet steel, rectangular</i>	40215
ⓑ Tennis	15590	Board(s):		ⓑ <i>Fuel storage, hand-portable safety type, 24-gauge or thicker sheet steel, with flash arrester, other than rectangular</i>	40217
ⓑ Water polo, inflated, official or regulation size and weight	15560	ⓑ <i>Arch</i>	142060	Caps:	
Band(s):		ⓑ <i>Clip</i>	179180	ⓑ <i>Bottle, can, cup, collapsible tube, glass, jar or jug</i>	40230, 40240, 40255, 40265, 40290, 40300, 40310, 40320, 40330, 40350, 40360, 40370, 40390, 156600
ⓑ <i>Bottle, can, cup, collapsible tube, glass, jar or jug</i>	40230, 40235, 40265, 40300, 40310, 40320, 40330, 40350, 40390, 156600	ⓑ <i>Oil, paper</i>	151170	ⓑ <i>Dispensing, for pressurized cans or bottles</i>	40290
Ⓐ Heat-shrinkable tubular plastic film, cut to size	40225	ⓑ <i>Take-off, track or field house, wood</i>	17688		
Ⓐ NOI, for bottles, cans, cups, collapsible tubes, glasses, jars or jugs	40225	ⓑ <i>Toe, track or field house, wood</i>	17688		
		ⓑ <i>Toy building or construction, wood, cut to length, notched, in the white</i>	83985		
		Ⓐ Boat Polish or Wax, not required by DOT to bear a Hazard Class or Hazard Division label or placard	160460		
		Bodies:			
		ⓑ <i>Doll</i>	84100		
		Boilers:			
		ⓑ <i>Canning, iron</i>	52920		
		Books:			
		ⓑ <i>Agenda or appointment</i>	178910		
		Ⓐ <i>Agenda or appointment, NOI</i>	179180		
		ⓑ <i>Trading stamp collection, scrap or waste, containing stamps cancelled by perforation</i>	151390		

INDEX TO ARTICLES

Article	Item	Article	Item	Article	Item
Caps: (Cont'd)		Chutes:		Cookers:	
ⓑEnd, eave trough or roof gutter, aluminum, copper, iron, lead, steel, tinplate or zinc.....	36410	ⓑSpraying, livestock.....	65930	ⓑPressure, household, other than electric.....	52960
ⓑMilk bottle, aluminum foil or aluminum foil and paper, nested.....	40360	ⓐCider, fruit, including Cider Concentrates, nonalcoholic, other than frozen.....	73260	ⓐPressure, other than electric.....	52880
ⓑMilk bottle, pulpboard.....	40370	ⓑCircles:		ⓑCookware, metal, NOI.....	52880
ⓐNOI, for bottles, cans, cups, collapsible tubes, glasses, jars or jugs.....	40225	ⓑAiming, ordnance, metal and glass.....	145970	ⓐCookware, metal, NOI, other than electric or gas.....	52880
ⓑToy pistol and cap pistol.....	84000	ⓑDiscus or shot-putting, steel, hinged, folded.....	17690	Corn:	
ⓐCard Games.....	84260	ⓑPewter.....	135625	ⓐGrain.....	89230
Cards:		ⓐCircles, aiming, ordnance, metal and glass.....	145970	ⓑNOI.....	89070
ⓑIndex, paper, scrap or waste.....	151390	ⓐCircles, pewter.....	135625	Corn Poppers:	
ⓐPlaying.....	84260	Clamps:		ⓑHousehold, other than electric.....	52904
ⓑTabulating, paper, scrap or waste.....	151390	ⓑVertical filing.....	142050	Corners:	
Carriers:		ⓑCleaner, shoe.....	58420	ⓑEave trough or roof gutter, aluminum, copper, iron, lead, steel, tinplate or zinc.....	36410
ⓑFlexible intermediate bulk container, fiberboard, paperboard or pulpboard.....	150310	Cleaners:		ⓑCoroa, fibers.....	68240
ⓐCatalytic Converters, internal combustion engine exhaust system.....	125850	ⓐShoe, not required by DOT to bear a Hazard Class or Hazard Division label or placard.....	160460	Covers:	
Cement(s):		ⓐClipboards, including Storage Clipboards.....	179180	ⓑBook, flexible paper (paperback book), including part covers, scrap or waste, density 30 pcf or greater.....	151390
ⓐAdhesive, NOI, not required by DOT to bear a Hazard Class or Hazard Division label or placard.....	4625	Cloth(s):		ⓑBottle, can, cup, collapsible tube, glass, jar or jug.....	40230, 40255, 40265, 40290, 40300, 40310, 40320, 40330, 40350, 40375, 40390, 156600
Chalk:		ⓑPolishing, cotton, wax or chemically treated.....	49280	ⓑDispensing, for pressurized cans or bottles.....	40290
ⓐDrawing or marking, NOI.....	179180	ⓐTreated or impregnated with polish or wax.....	160460	ⓑMagazine, including part covers, scrap or waste.....	151390
ⓑMarking, other than pastels.....	178920	ⓑClubs, golf.....	16530	ⓑMounting, sheet steel, for pressurized can or bottle caps, covers or tops.....	40375
ⓑSchool, other than pastels.....	178920	ⓐClubs, sports.....	15520	ⓐNOI, for bottles, cans, cups, collapsible tubes, glasses, jars or jugs.....	40225
ⓐWriting, NOI.....	179180	Compound(s):		ⓐSeat, automobile.....	18460
ⓐChalkboards.....	23700	ⓑBuffing, impregnated into paper or cloth.....	33430	ⓑCrayons, school or marking, other than artists'.....	178930
ⓑChalkboards, NOI.....	23700	ⓑBuffing, NOI.....	33440	ⓐCrayons, writing, marking or drawing, NOI.....	179180
ⓑChalkboards, portable, revolving or reversible, on stands.....	79110	ⓐBuffing, NOI, not required by DOT to bear a Hazard Class or Hazard Division label or placard.....	160460	Crystals:	
ⓑChalkboards, Stands and Seats combined, plastic, steel and masonite, KD flat.....	79132	ⓑModeling, toy.....	84510	ⓑFruit juice.....	73360
ⓑChalkboards, Stands and Seats combined, wood or wood and steel, KD flat.....	79135	ⓑPolishing, impregnated into paper or cloth.....	33430	ⓐJuice.....	73260
ⓑCharcoal:		ⓑPolishing, NOI.....	33440	Cushions:	
ⓑCoconut shell, nut shell, NOI, or fruit pit, not activated, not required by DOT to bear a Hazard Class or Hazard Division label or placard.....	42450	ⓐPolishing, NOI, not required by DOT to bear a Hazard Class or Hazard Division label or placard.....	160460	ⓑExercise.....	16835
ⓑNOI, not activated, not required by DOT to bear a Hazard Class or Hazard Division label or placard.....	42445	Concentrate(s):		ⓑGymnastic or jumping pit.....	16835
ⓑWood, in tablets.....	58610	ⓐFruit cider, nonalcoholic, other than frozen.....	73260	ⓑToboggan.....	16080
ⓑCharcoal Briquettes, coconut shell, nut shell, NOI, or fruit pit, not activated, not required by DOT to bear a Hazard Class or Hazard Division label or placard.....	42450	ⓐFruit juice, other than frozen.....	73260	ⓑCutoffs, conductor pipe (downspout):	
ⓑCharcoal Briquettes or Charcoal Pellets, NOI, not activated, not required by DOT to bear a Hazard Class or Hazard Division label or placard.....	42445	ⓐVegetable juice, other than frozen.....	73260	ⓑAluminum.....	36180
ⓐCharcoal, Charcoal Briquettes or Charcoal Pellets, NOI, not activated, not required by DOT to bear a Hazard Class or Hazard Division label or placard.....	42445	Conditioner(s):		ⓑCopper, lead or zinc.....	36190
ⓐCharcoal, wood, in tablets.....	58610	ⓐLeather, not required by DOT to bear a Hazard Class or Hazard Division label or placard.....	160460	ⓑIron, steel or tin plate.....	36210
ⓑCheckers, Checkerboards or Checker Games.....	84040	Connections:			
ⓑChewing Gum Base.....	91260	ⓑConductor pipe, cast iron.....	36220	D	
ⓐChicle.....	91650	Connectors:		ⓑDay Planners.....	178910
		ⓑSlip joint, eave trough or roof gutter, aluminum, copper, iron, lead, steel, tinplate or zinc.....	36410	ⓐDay Planners, NOI.....	179180
		Containers:		ⓑDecoys, bird, mechanical.....	16100
		ⓐFuel or flammable liquid storage or dispensing, hand portable.....	174610	ⓐDesk Accessories, NOI, including Desk Blotters or Desk Pads.....	179180
		ⓑFuel storage, 20-gauge or thicker sheet steel, rectangular.....	40215	Devices:	
		ⓑFuel storage, hand-portable safety type, 24-gauge or thicker sheet steel, with flash arrester, other than rectangular.....	40217	ⓑCatalytic, internal combustion engine exhaust system.....	57170
		Converters:		ⓑDirectories, paper, scrap or waste.....	151390
		ⓐCatalytic, internal combustion engine exhaust system.....	125850	Discs (also see 'Disks'):	
				ⓑBottle, can, cup, collapsible tube, glass, jar or jug.....	40230, 40255, 40265, 40300, 40320, 40330, 40350, 40390, 156600
				ⓑHovering, plastic, other than expanded.....	17200

INDEX TO ARTICLES

Article	Item	Article	Item	Article	Item
Glue(s):		Ⓐ Horseshoes, iron or steel or iron or steel and rubber	96720	Markers: (Cont'd)	
Ⓒ Adhesive, NOI, not required by DOT to bear a Hazard Class or Hazard Division label or placard	4625	Ⓑ Hurdles, track, metal or wood, crossbars of same or other materials	17694	Ⓑ Lane, swimming pool	16810
Ⓑ Casein	4637			Ⓐ Marking, NOI	179180
Ⓑ Goals, basketball	16430	I		Ⓑ Mechanical crayon	179120
Ⓐ Grain, NOI	89230	Ⓐ Ink Pads	179180	Masks:	
Ⓑ Griddles:		Ⓑ Inkstands	179020	Ⓑ Aperture, color cathode ray tube, unfinished sheets, steel	62515
Ⓑ Commercial or institutional type, gas or electric, iron or steel, gross shipping weight exceeding 500 lbs. each	25970	Ⓑ Inkwells	179020	Ⓑ Baseball	16820
Ⓑ Electric, NOI	62128	Ⓑ Inkwells and pens	178970	Ⓑ Fencing	16820
Ⓑ Frying, aluminum, magnesium or sheet steel, other than electric	52910			Ⓐ Sports	15520
Ⓐ Griddles, commercial or institutional type, gas or electric, iron or steel, gross shipping weight exceeding 500 lbs. each	25970	J		Mats:	
Ⓐ Griddles, electric, NOI	62128	Jackets:		Ⓒ Exercise	149265
Gum(s):		Ⓐ File, NOI	179180	Ⓒ Gymnastic	149265
Ⓑ Arabic	91180	Ⓑ Jackstones	84410	Ⓑ Jumping pit	16835
Ⓑ Copal	91300	Juice(s):		Ⓑ Mats, target, hay, grass, straw or wood excelsior	17560
Ⓑ Damar	91320	Ⓒ Fruit, including Juice Concentrates, Juice Beverages or Juice Drinks, other than frozen	73260	Meal:	
Ⓑ Demar	91320	Ⓒ Vegetable, including Juice Concentrates, Juice Beverages or Juice Drinks, other than frozen	73260	Ⓑ Gluten	89670
Ⓑ Ester	91360			Ⓑ Wheat germ	89770
Ⓑ Karaya	91420	K		Ⓑ Merry-go-rounds, miniature, KD	84470
Ⓑ Manila	91460	Kettles:		Ⓑ Mitres (Corners), eave trough or roof gutter, aluminum, copper, iron, lead, steel, tinplate or zinc	36410
Ⓑ Natural	91380	Ⓑ Canning, iron	52920	Ⓐ Mitts, baseball, boxing or softball	15520
Ⓐ Natural, NOI	91650	Ⓐ Kites, toy	84260	Ⓑ Modeling Compound, toy	84510
Ⓑ Pontianac	91500	Ⓑ Kites, toy, other than cellular, expanded or foam plastic	84451	Ⓑ Moisteners, envelope or postage stamp	142400
Ⓑ Shellac	91540	Kits:		Mounts:	
Ⓑ Spruce	91560	Ⓐ Pool, NOI	15520	Ⓑ Calendar	178910
Ⓑ Turpentine	91600	Ⓑ Swimming pool, above-ground or semi-inground, NOI	17050	N	
Guns:		Ⓑ Wading pool, above-ground or semi-inground, NOI	17050	Napkins:	
Ⓑ Air	84340			Ⓑ Sanitary	59230
Ⓐ BB	15520			Ⓐ Sanitary, feminine hygiene	59413
Ⓑ B-B	17100	L		Nets:	
Ⓐ Cap	84260	Ⓑ Lard:		Ⓐ Sports, NOI	15520
Ⓐ Dart	84260	Ⓑ Benzoinated	58920	Ⓑ Tennis	16950
Ⓑ Toy	84340, 84360, 84810	Ⓑ Leaf, not rendered	134550	Ⓑ Newspapers, scrap or waste	151390
Ⓐ Toy or water	84260	Ⓑ NOI	134530	Nuts:	
Gutters:		Ⓐ Lard, leaf, not rendered	134550	Ⓑ Areca, ground or powdered	59040
Ⓑ Roof, aluminum, copper, iron, lead, steel, tinplate or zinc	36410	Ⓐ Lard, NOI	134530	Ⓑ Areca, not ground nor powdered	59050
Ⓐ Roof, metal	37020	Ⓑ Lashing, jute	68400	Ⓑ Betel, ground or powdered	59040
Ⓑ Roof, wooden, in the rough	112480	Ⓐ Leather Polish, Dressing or Conditioners, not required by DOT to bear a Hazard Class or Hazard Division label or placard	160460	Ⓑ Betel, not ground nor powdered	59050
H		Lids:		O	
Hair:		Ⓑ Bottle, can, collapsible tube, glass, jar or jug	40230, 40305, 40310, 40320, 40330, 40350, 40390	Ⓒ Oats	89230
Ⓑ Coir	68290	Ⓐ NOI, for bottles, cans, cups, collapsible tubes, glasses, jars or jugs	40225	Ⓐ Office Supplies – as listed	179180
Hammers:		Lifters:		Ⓑ Oil Board, paper	151170
Ⓑ Throwing, track or field house	17693	Ⓐ Loose-leaf	179180	Oil(s):	
Heads:		Ⓑ Loose-leaf binder sheet	179055	Ⓒ NOI, petroleum, not required by DOT to bear a Hazard Class or Hazard Division label or placard	155250
Ⓑ Doll	84100	Line(s):		Ⓑ Outlets, eave trough or roof gutter, aluminum, copper, iron, lead, steel, tinplate or zinc	36410
Ⓐ Sprinkler	178090	Ⓑ Fishing	16270	P	
Ⓑ Sprinkler, automatic fire extinguisher	178080			Packing:	
Ⓑ Sprinkler, pulsating, metal	178095			Ⓑ Paper	151190
Holders:				Ⓑ Paddles, toy, wood, with rubber balls or vacuum caps attached	84980
Ⓑ Pen	179120	M		Pads:	
Ⓐ Tape	179180	Machinery or Machines:		Ⓑ Date	178910
Ⓑ Tape, NOI	178980	Ⓑ Football blocking	16330	Ⓐ Desk	179180
Hooks:		Magazines:		Ⓑ Desk blotter, pulpboard, with blotter retainers of fabric, paper or pulpboard	153730
Ⓑ Fish	16255	Ⓑ Printed, old; scrap or waste	151390	Ⓑ Desk, calendar	178910
Ⓑ Gaff	16650	Markers:		Ⓑ Exercise	16835
Ⓑ Horseshoes:		Ⓑ Bingo game	179057	Ⓐ Feminine hygiene	59413
Ⓑ Aluminum	13503	Ⓐ Drawing, NOI	179180	Ⓑ Gymnastic	16835
Ⓑ Iron or steel or iron or steel and rubber	96720				
Ⓑ Pitching	16660				
Ⓐ Horseshoes, aluminum	13503				

INDEX TO ARTICLES

Article	Item	Article	Item	Article	Item
Pads: (Cont'd)		Paper(s): (Cont'd)		Paper(s): (Cont'd)	
Ⓐ Ink	179180	ⓑ Envelope lining, printed	151110	ⓑ Wrapping, decorative, in rolls less than 50 feet per roll	151780
ⓑ Inking	179065	ⓑ Fiber-stock	150950	ⓑ Wrapping, NOI, other than corrugated, fluted or indented	151800
ⓑ Jumping pit	16835	ⓑ Filter stock	150970	ⓑ Writing, folded	151820
ⓑ Memorandum, desk	179070	ⓑ Flock coated	151230	ⓑ Writing, other than folded, not printed	150670
ⓑ Sanitary	59230	ⓑ Folded and pressed into strips	150700	Ⓒ Paperweights	179180
Ⓐ Stamping	179180	ⓑ Gift wrapping, in rolls 50 feet or more per roll, or other than in rolls	151800	Ⓒ Parchment	150550
Ⓐ Treated or impregnated with polish or wax	160460	ⓑ Gift wrapping, in rolls less than 50 feet per roll	151780	Parts:	
Pallets:		ⓑ Glazed, NOI	150930	ⓑ Dispensing cap, cover or top, for pressurized cans or bottles, assembled, NOI	40290
ⓑ Flexible intermediate bulk container, fiberboard, paperboard or pulpboard	150310	ⓑ Government pulp	150990	ⓑ Golf club	16530
ⓑ Lift truck, aluminum	150370	ⓑ Ground wood	151010	Ⓐ Pools or pool kits, NOI	15520
ⓑ Lift truck, corrugated fiberboard and corrugated fiberboard-faced wood, veneer or plywood, in sheets, not assembled nor set up	150380	ⓑ Gummed	151030	ⓑ Swimming pool or pool kit, NOI	17050
ⓑ Lift truck, corrugated fiberboard, paperboard or pulpboard with molded plastic legs, nested	150433	ⓑ Imitation colored glass	151050	ⓑ Wading pool or pool kit, NOI	17050
ⓑ Lift truck, fiberboard and cellular, expanded or foam plastic	150435	ⓑ Imitation stained glass	151050	Paste(s):	
ⓑ Lift truck, fiberboard, paperboard or pulpboard	150430	ⓑ Inked for magnetic printing	179150	Ⓒ Adhesive, NOI, not required by DOT to bear a Hazard Class or Hazard Division label or placard	4625
ⓑ Lift truck, plastic, steel or wood	150390	ⓑ Lace	151070	ⓑ Pegboards, Stands and Seats combined, plastic, steel and masonite, KD flat	
Ⓐ NOI	150400	ⓑ Latex impregnated	151240	ⓑ Pegboards, Stands and Seats combined, wood or wood and steel, KD flat	
ⓑ Shipping, molded wood fiber or wood particles, with plastic resin binder, nested	150345	ⓑ Matrix	150670	ⓑ Pegs, golf	
ⓑ Spill containment, lift truck, plastic, steel or wood	150390	ⓑ Napkin, in nonperforated rolls, as from the mill, used to make paper napkins	151460	ⓑ Pegs, horseshoe pitching	
ⓑ Pamphlets, scrap or waste		ⓑ Newsprint	151130, 151150	ⓑ Pencils:	
ⓑ Paperboard:		ⓑ NOI, corrugated, fluted or indented	151315	ⓑ Lead, wooden	179050
ⓑ Flock coated or printed with flock	151230	Ⓒ NOI	150550	ⓑ Paper wrapped	179120
ⓑ NOI, corrugated, fluted or indented	151315	ⓑ NOI, not printed	151250	ⓑ Slate	179120
ⓑ NOI, not corrugated, fluted nor indented	151320	ⓑ Oil board	151170	Ⓐ Pen or Pencil Sets	
ⓑ Synthetic fiber	154555	ⓑ Packing	151190	Ⓐ Pencils, writing, marking or drawing, NOI	
Ⓐ Paperboard, NOI		Ⓐ Parchment	150550	Pens:	
Ⓐ Paperboard, synthetic fiber		ⓑ Pari-mutuel ticket issuing machine	151270	Ⓐ Drawing, NOI	179180
Paper(s):		ⓑ Phenolic resin impregnated	151280	ⓑ Livestock spraying, NOI, wood and steel combined	65930
ⓑ Absorbent base, for impregnation and making laminated plastics	150620	ⓑ Photographic, sensitized	151290	Ⓐ Marking or writing, NOI	179180
ⓑ Autographic register	150650	ⓑ Polishing	151210	ⓑ Writing, NOI	179180
ⓑ Blotting	150670	ⓑ Printed with flock	151230	ⓑ Pens and bases	
ⓑ Blueprint	150690	Ⓒ Printer, computer	150550	ⓑ Pens and inkwells	
ⓑ Box cover or lining, printed	150890	ⓑ Printing, other than newsprint or carbonized print, NOI	150670	Percolators:	
ⓑ Braided	150700	ⓑ Printing, other than newsprint or carbonized print, rejected	151300	ⓑ Coffee, household, sheet steel, enameled, other than self-heating	52940
ⓑ Calculator	150650	ⓑ Reproduction	150690	ⓑ Copper, NOI, other than electric	52950
ⓑ Calendar roll	150720	ⓑ Resin impregnated	151370	Ⓐ Metal, NOI, other than electric or gas	52880
Ⓐ Carbon	150550	ⓑ Scrap	151390	ⓑ Sheet steel, NOI, other than electric	52950
ⓑ Carbon, NOI	150740	ⓑ Shelf covering, combined with foil and plastic	151395	Pieces:	
ⓑ Carbon, single or one-time use	150780	ⓑ Stereotype	150670	ⓑ End, eave trough or roof gutter, aluminum, copper, iron, lead, steel, tinplate or zinc	36410
ⓑ Carbonized for magnetic printing	179150	ⓑ Store decorative	151400	Pins:	
ⓑ Carbonized newsprint	150780	ⓑ Store display	151400	Ⓐ Bowling, NOI	15520
ⓑ Carbonizing	150760	ⓑ Suitcase cover or lining, printed	150890	ⓑ Bowling, other than hollow molded plastic	15940
ⓑ Cash register	150650	ⓑ Surface coated, NOI	150930	Pipe(s):	
ⓑ Chemically hardened fiber making	150950	ⓑ Ticket issuing machine	150650	ⓑ Conductor (downspout), aluminum	36180
ⓑ Cloth lined	150850	ⓑ Tipping, cigarette	150805	ⓑ Conductor (downspout), copper, lead or zinc	36190
ⓑ Computer or computer printer	150650	ⓑ Tissue, NOI, other than tissue wrapping paper	151440	ⓑ Conductor (downspout), iron, steel or tin plate	36210
Ⓒ Copying machine	150550	ⓑ Toilet, in nonperforated rolls, as from the mill, used to make toilet paper	151460	Pins:	
ⓑ Cover	150670	ⓑ Trunk cover or lining, printed	150890	Ⓐ Push	179180
ⓑ Crepe, tissue, NOI, other than streamers	150910	ⓑ Twisted	150700	ⓑ Pistol(s):	
ⓑ Data processing machine	150650	ⓑ Vegetable parchment lining	151500	ⓑ Air, NOI	17110
ⓑ Document manila	150670	ⓑ Vegetable parchment, NOI	151520	ⓑ Air, spring-powered	17100
ⓑ Drawer lining, combined with foil and plastic	151395	ⓑ Vegetable parchment wrapping	151500	ⓑ Cap and toy pistol caps	84000
ⓑ Drawing	150670	ⓑ Waste, ground	151620		
ⓑ Dusting	151210	ⓑ Waste, NOI	151390		
ⓑ Enameled, NOI	150930	Ⓒ Waxed	150550		
		ⓑ Window decorative	151400		
		ⓑ Window display	151400		
		ⓑ Window shade	151640		
		ⓑ Wrapping, decorative, in rolls 50 feet or more per roll, or other than in rolls	151800		

INDEX TO ARTICLES

Article	Item	Article	Item	Article	Item
Pistol(s): (Cont'd)		Preparations:		Rum, bay	58560
ⓑGas powered, NOI	15520	ⒶBeverage, NOI	73260	ⒸRye	89230
ⒶPistols, air or gas powered, NOI	15520	ⓑBeverage, NOI, other than straws containing beverage preparations...	74490	S	
ⒶPlanners, day, NOI	179180	ⓑPressure Cookers, household, other than electric	52960	ⒶSandboxes	15520
ⓑPlanners, day or student	178910	ⒶPressure Cookers, other than electric	52880	ⓑSandboxes, children's playground, NOI	17160
Plates:		Protectors:		ⓑSandboxes, molded plastic	15520
ⓑHome, baseball or softball	15620	ⒶLoose-leaf	179180	ⓑSanitary Napkins or Pads	59230
ⓑPitchers', baseball or softball	15620	ⓑLoose-leaf binder sheet	179055	ⒶSanitary Napkins, feminine hygiene	59413
Platforms:		ⓑPucks, hockey	16620	ⓑSaucers:	
ⓑGolf practice, mechanical	16550	Pulp:		ⓑCoasting, steel, nested	189025
ⓑLift truck, aluminum	150370	ⓑMacerated paper currency	150990	ⓑFlowerpot, pottery	47550
ⓑLift truck, corrugated fiberboard and corrugated- fiberboard-faced wood, veneer or plywood, in sheets, not assembled nor set up.	150380	ⒶPulpboard, NOI	150550	ⓑThrowing or hovering, plastic, other than expanded	17200
ⓑLift truck, corrugated fiberboard, paperboard or pulpboard with molded plastic legs, nested	150433	ⓑPulpboard, NOI, corrugated, fluted or indented	151315	ⒶSaucers, coasting, steel, nested	189025
ⓑLift truck, fiberboard and cellular, expanded or foam plastic	150435	ⓑPulpboard, NOI, not corrugated, fluted nor indented	151320	ⒶSaucers, flowerpot, pottery	47550
ⓑLift truck, fiberboard, paperboard or pulpboard	150430	ⒶPumice	162920	Scrap(s):	
ⓑLift truck, plastic, steel or wood	150390	ⒶPush Pins	179180	ⓑPaper	151390
ⒶNOI	150400	Q			
ⓑPlayhouses, KD flat	84600	ⓑQuoits	17060	Sets:	
Plugs:		R			
ⓑEraser stock	178995	ⒶRackets, sports	15520	ⓑBaking, consisting of glass baking dishes and plastic microwave cooking dishes or racks	52980
Pockets:		Racks:		ⓑChildren's paper or paperback book and recorded cassette tape	84690
ⒶFile, NOI	179180	ⓑFeed, wooden	65740	ⓑChildren's school pencil or pen holder	179120
ⓑLetter, document or invoice, paper, pulpboard or paper or pulpboard and wood	142085	ⒶShipping, NOI	150400	ⓑConstruction, toy, metal, completely disassembled	84700
Points:		ⓑShipping, NOI, lift truck, plastic, steel or wood	150390	ⓑCooking, consisting of glass baking dishes and plastic microwave cooking dishes or racks	52980
ⓑArchery arrow	16985	ⓑRejections, jute	68400	ⓑCroquet	16040
ⓑPen	179140	Resin(s):		ⓑDesk pen	178970
Poles:		ⓑEpoxy, electrically conductive, containing gold or silver	4630	ⓑModeling, toy	84702
ⓑFishing	15520	ⓑRetorts, canning, iron	52920	ⒶPen or pencil	179180
ⓑSki	17330	ⓑRibbon(s):		ⓑRecord and book	84710
Polish:		ⓑCarbonized, for magnetic printing	179150	ⓑRoad race	84705
ⒶAutomobile, boat, floor, furniture or leather, shoe or vehicle, not required by DOT to bear a Hazard Class or Hazard Division label or placard	160460	ⓑCloth or fabric, NOI	49020	ⓑToy block building	84790
ⓑBoat, floor, furniture or vehicle, impregnated into paper or cloth	33430	ⓑInked, for magnetic printing	179150	ⓑToy dish, glass or pottery	84080
ⓑBoat, floor, furniture or vehicle, NOI	33440	ⓑInked, NOI, including Typewriter Ribbons	179160	Shafts:	
ⒶNOI, not required by DOT to bear a Hazard Class or Hazard Division label or placard	160460	ⒶRibbons, cloth or fabric, NOI	49020	ⓑGolf club, aluminum or steel, unfinished	16520
ⓑStove	58420	ⒶRibbons, inked, NOI	179180	Sheet(s):	
Polishers:		Rifles:		ⓑMemorandum, paper, in plastic holders	179175
ⓑLeather	160450	ⓑAir, NOI	17110	ⒶShipping Racks, NOI	150400
ⓑVinyl	160450	ⒶAir powered, NOI	15520	ⒶShoe Polish, Dressing, Cleaners or Wax, not required by DOT to bear a Hazard Class or Hazard Division label or placard	160460
ⒶPolishing Compounds or Polishing Wax, NOI, not required by DOT to bear a Hazard Class or Hazard Division label or placard	160460	ⓑAir, spring-powered	17100	Shoes:	
ⓑPools or Pool Kits, swimming or wading, above-ground or semi- inground, NOI	17050	ⓑAir, toy, firing hollow projectiles	84340	ⓑConductor pipe (downspout), aluminum	36180
ⒶPools or Pool Kits, NOI	15520	ⓑGas powered	17110	ⓑConductor pipe (downspout), copper, lead or zinc	36190
ⓑPools, wading, molded plastic	15520	ⒶGas powered, NOI	15520	ⓑConductor pipe (downspout), iron, steel or tin plate	36210
Popcorn:		ⓑToy, NOI	84360	ⓑHorse, pitching	16660
ⓑIn the ear, not popped, NOI	89150	Rims:		ⓑSnow	15520
Poppers, corn:		ⒶBasketball	15520	ⓑShuttlecocks, badminton	17260
ⓑHousehold, other than electric	52904	Rings:		ⓑSinkers, lead	17290
Posts:		ⓑBottle, can, cup, collapsible tube, glass, jar or jug	40230, 40265, 40310, 40320, 40330, 40350, 40390, 156600	ⓑSkateboards	15520
ⓑTennis	17056	ⒶNOI, for bottles, cans, cups, collapsible tubes, glasses, jars or jugs	40225	ⓑSkates, ice, in-line or roller	15520
Powder(s):		Rod(s):		ⓑSki Poles	17330
ⓑFruit juice	73360	ⓑEraser stock	178995	Skids:	
ⒶJuice	73260	ⓑFishing	15220	ⓑLift truck, aluminum	150370
		ⓑRoof Gutters, aluminum, copper, iron, lead, steel, tinplate or zinc	36410	ⓑLift truck, corrugated fiberboard and corrugated- fiberboard-faced wood, veneer or plywood, in sheets, not assembled nor set up.	150380
		ⒶRoof Gutters, metal	37020		
		ⓑRoof Gutters, wooden, in the rough	112480		
		Rope(s):			
		ⓑWater Skiing	15520		

Only participants in the NMFC at the time the transportation occurs may use the provisions herein.

For explanation of abbreviations and reference marks, see last page of this Supplement. ©NMFTA 2023

INDEX TO ARTICLES

Article	Item	Article	Item	Article	Item
Wrappers:		Wrappers: (Cont'd)		Y	
Ⓐ Heat-shrinkable tubular plastic film, cut to size	40225	Ⓑ Paper, NOI	151660	Ⓑ Yo-Yo's, not exceeding 3 ¹ / ₂ inches in diameter	84750
Ⓑ Heat-shrinkable tubular plastic film, cut to size, KD flat	40235	Ⓑ Vegetable parchment	151680		

RULES

ITEM 180-A

PERFORMANCE TESTING OF SHIPPING CONTAINERS

This rule provides an alternative to the other packaging rules (except those relating to drums, pails and bags) and the Numbered Packages. It is recommended for solving chronic damage problems and for providing an acceptable assurance level of packaging for articles of great value. In order to qualify as authorized methods of packaging under this rule, shipping containers, including palletized loads, must be preshipment tested and successfully pass the following prescribed performance test requirements and meet the acceptance criteria as indicated.

Shippers will be required to perform the specified minimum tests as often as necessary to maintain a satisfactory performance level of the packaged article (see Section VII. Certification). Multiple test specimens are recommended when available and all specimens tested must pass.

This rule does not purport to address all of the safety issues, if any, associated with its use. It is the responsibility of the user of this rule to establish appropriate safety and health practices and to determine the applicability of regulatory limitations or requirements prior to use.

Orientation and Nomenclature for Test Specimens Consisting of a Shipping Container without Lift Truck Skid or Pallet Outside Base: For test specimens consisting of a shipping container not on or not having a lift truck skid or pallet outside base, place the container in its normal shipping orientation with the front facing forward and then proceed with marking the faces according to the diagram shown below. Note the Manufacturer's Joint, when present, may or may not be located in the same position as shown in the diagram.

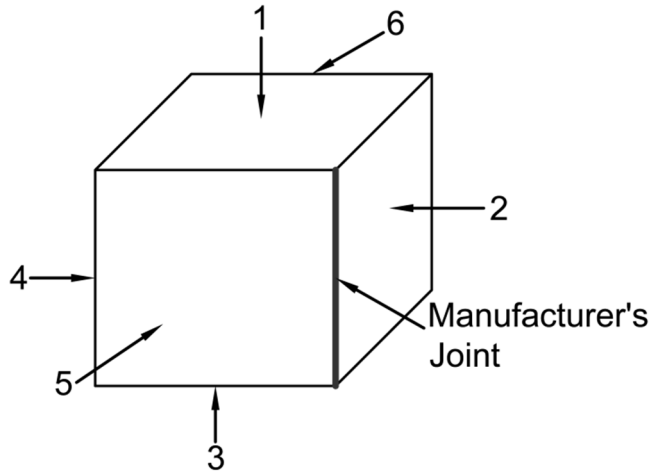

Orientation and Nomenclature for Test Specimens with Lift Truck Skid or Pallet Outside Base: For test specimens consisting of one or more shipping containers on or having a lift truck skid or pallet outside base, place the shipping unit in its normal shipping orientation with the front facing forward. Use the diagram below to determine the dimensions of the product(s), and the overall dimensions of the shipping unit.

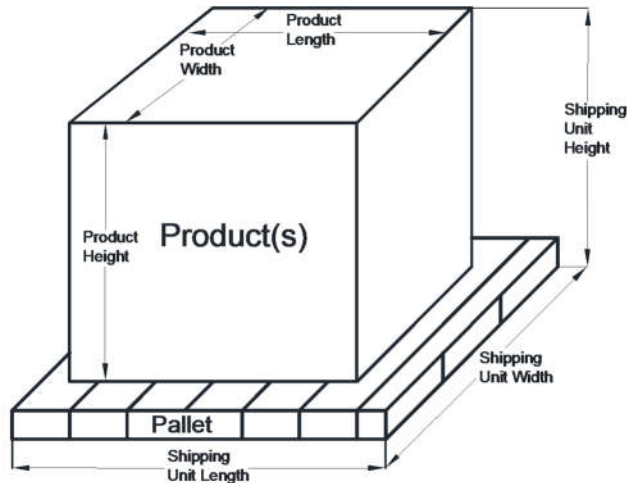

PERFORMANCE TEST REQUIREMENTS: All applicable shipping units must be tested as follows:

Section I. Conditioning

Except as provided in Note 1, all specimens must be conditioned in an atmosphere of 73°F (23°C) minimum and 50% RH minimum for at least 24 hours for paper-based packaging and 12 hours for all others. Testing should be conducted in the same minimum atmosphere, and conditions must be recorded for each test conducted. If testing cannot be conducted in the minimum atmosphere, conduct the tests as soon as possible after the packaged products have been stored for 24 hours in the testing environment.

NOTE 1—Alternatively, fiberboard packaging may be conditioned in an atmosphere of 40°F (4°C) and 85% RH or 100°F (38°C) and 85% RH for at least 72 hours.

(Continued on following page)

RULES

ITEM 180-A-Continued

Section II. Compression/Vibration Test

Two alternate methods of testing are permissible: Method (A)—Stacked Compressive Load/Vibration Testing, or Method (B)—Separate Compressive Load/Vibration Testing. Either may be utilized, depending on test capability or product characteristics. Unless the shipping container has a lift truck skid or pallet outside base, or is marked with upright arrow symbols, the container must be tested on Faces 3, 4 and 6. If the shipping unit has either a lift truck skid or pallet outside base or is marked with upright arrow symbols, the compressive load or force requirements in Methods (A) and (B) for Faces 4 and 6 may be omitted. If the shipping unit is 6 ft (1.83 m) or taller in height, and has a lift truck skid or pallet outside base, the compressive load or force requirements in Methods (A) and (B) may be omitted.

Method (A)—Stacked Compressive Load/Vibration Testing

Shipping units must be vibration tested under a stacked compressive load using either an identical shipping unit, or a concentrated dead weight load as described below.

(1) **Calculating Concentrated Dead Weight Loads:** When conducting concentrated dead weight load vibration tests, the size of the package changes with the three shipping orientations of the package, and the concentrated dead load weights on the top of the package will change accordingly. Use a concentrated dead load (see Description of Load Apparatus in Paragraph (2)(a) below) to simulate miscellaneous freight loaded on top of a floor-stowed shipping unit in a trailer. Determine the required loads, rounded to the nearest 5 pounds (lbs), from the formulas in Table 1 or 2:

Table 1: Method (A) Load Calculation

Orientation — Face 3 Down:

$$\text{LOAD} = \frac{10 \times (108 - h) \times (l \times w)}{1728}$$

Orientation — Face 4 Down:

$$\text{LOAD} = \frac{10 \times (108 - w) \times (l \times h)}{1728}$$

Orientation — Face 6 Down:

$$\text{LOAD} = \frac{10 \times (108 - l) \times (w \times h)}{1728}$$

Where:	LOAD =	pounds (lbs)
	10 =	average density of LTL freight (pcf)
	108 =	inside height of trailer (in), see Note 2
	1728 =	conversion factor (in ³ /ft ³)
	h =	height of product(s) or shipping unit (in)
	l =	length of product(s) (in)
	w =	width of product(s) (in)

Table 2: Method (A) Load Calculation (Metric)

Orientation — Face 3 Down:

$$\text{LOAD} = 162 \times (2.7 - h) \times (l \times w) \times 9.8$$

Orientation — Face 4 Down:

$$\text{LOAD} = 162 \times (2.7 - w) \times (l \times h) \times 9.8$$

Orientation — Face 6 Down:

$$\text{LOAD} = 162 \times (2.7 - l) \times (w \times h) \times 9.8$$

Where:	LOAD =	kilograms (kg)
	162 =	average density of LTL freight (kg/m ³)
	2.7 =	inside height of trailer (m), see Note 2
	h =	height of product(s) or shipping unit (m)
	l =	length of product(s) (m)
	w =	width of product(s) (m)
	9.8 =	metric conversion factor (m/s ²)

NOTE 2—If the package weighs less than 30 lbs (14 kg) or is 2 ft³ (0.056 m³) or less in size, the factor is reduced to 54 in (1.4 m) instead of 108 in (2.7 m).

(2)(a) **Description of Load Apparatus:** The concentrated dead load shall consist of the following: corrugated trays or HSC-style container(s) of doublewall construction having a corrugated medium maximum basis weight of 33 lbs (15 kg); a plywood sheet with a minimum thickness of 0.5 in (13 mm) resting inside the container on the complete area of the bottom inner flaps of the container; and a block of lead or sand contained in plastic bag(s) evenly distributed over the bottom surface of the container to complete the required calculated load (sand weighs approximately 110 pcf (50 kg/m³)). The dead load container(s) must be larger than the test specimen, but must not overhang the specimen by more than 1.5 in (38 mm). The dead load container(s) must be affixed so that it cannot move inside the perimeter of the test specimen during testing. The test specimen should not be fastened to the vibration table and should be allowed some lateral movement, yet restricted so that it does not move from under the perimeter of the dead load.

(Continued on following page)

RULES

ITEM 180-A-Continued

(2)(b) When test units have large top surfaces, i.e., any dimension exceeding 18 in (0.46 m), the dead load must be subdivided into smaller portions. If only one dimension exceeds 18 in (0.46 m), the load must be divided into two equal portions along the longer dimension. If both dimensions exceed 18 in (0.46 m), the load must be divided into four equal portions, as shown in the diagram below.

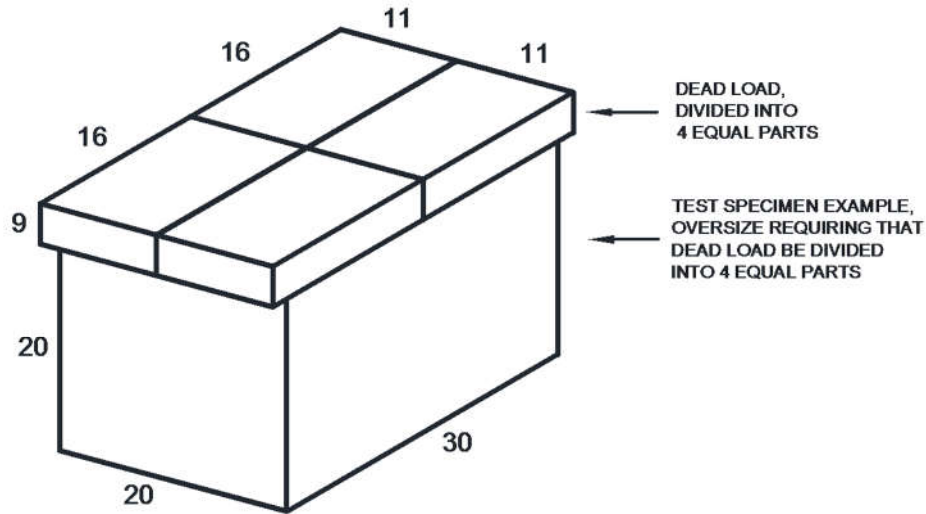

EXAMPLE OF CONCENTRATED DEAD LOAD ON TEST SPECIMEN FOR RANDOM VIBRATION TEST

TEST SPECIMEN SHOWN IN EXAMPLE MEASURES 30" X 20" X 20", LARGER THAN 18" IN BOTH LENGTH AND WIDTH, REQUIRING THAT THE DEAD LOAD BE DIVIDED INTO 4 EQUAL PARTS.

(3) **Vibration Testing:** Properly position either the identical shipping unit or the concentrated dead weight load on the shipping unit. Using procedure ASTM D4169 Schedule D, Assurance Level II, for random vibration under a stacked compressive load, test the shipping unit. Conduct the vibration testing on all three faces, except as noted below. Face 3 must be tested for one hour and Faces 4 and 6 must be tested for 30 minutes each, for a total duration of two hours. If the shipping unit has either a lift truck skid or pallet outside base or is marked with upright arrow symbols, only Face 3 must be vibrated under the compressive load for two hours.

Method (B)—Separate Compressive Load/Vibration Testing

Shipping units must be subjected to compression and vibration in separate tests. The compression test is conducted first and then the same shipping unit is vibration tested.

(1) **Compression Testing:** Except as noted below, compression testing is required to be conducted on Faces 3, 4 and 6 of the same shipping unit, using either a machine compression test (per ASTM D642) or a constant load (dead weight) test (per ASTM D4577), see Table 3. When conducting compression tests, the size of the package changes with the three shipping orientations of the package, so the required concentrated forces or dead loads on the top of the package will change accordingly. Using the formulas below in Table 4 or 5, calculate the required force or load, depending upon which compression method is used, for each of the three faces, rounded to the nearest 5 pounds force (lbf) or pounds (lbs), respectively. Apply the required compressive force or load on the shipping unit depending upon selected method found in Table 3. If the shipping container has a lift truck skid or pallet outside base, or is marked with upright arrow symbols, only Face 3 should be compressed.

Table 3: Compression Method

Compression Type	Length of Compression Time	Compression Value Designation
Machine Compression Test per ASTM D642	Remove immediately once required force is reached	FORCE
Constant Load (Dead Weight) Test per ASTM D4577	1 hour/face	LOAD

(Continued on following page)

RULES

ITEM 180-A-Continued

Table 4: Method (B) Force or Load Calculation

Orientation — Face 3 Down:

$$\text{FORCE or LOAD} = \frac{10 \times (108 - h) \times (l \times w) \times \text{DF}}{1728}$$

Orientation — Face 4 Down:

$$\text{FORCE or LOAD} = \frac{10 \times (108 - w) \times (l \times h) \times \text{DF}}{1728}$$

Orientation — Face 6 Down:

$$\text{FORCE or LOAD} = \frac{10 \times (108 - l) \times (w \times h) \times \text{DF}}{1728}$$

Where:	FORCE = or LOAD =	pounds force (lbf) or pounds (lbs)
	10 =	average density of LTL freight (pcf)
	108 =	inside height of trailer (in), see Note 3
	1728 =	conversion factor (in ³ /ft ³)
	h =	height of product(s) or shipping unit (in)
	l =	length of product(s) (in)
	w =	width of product(s) (in)
	DF =	Design Factor from Table 6

Table 5: Method (B) Force or Load Calculation (Metric)

Orientation — Face 3 Down:

$$\text{FORCE or LOAD} = 162 \times (2.7 - h) \times (l \times w) \times \text{DF} \times 9.8$$

Orientation — Face 4 Down:

$$\text{FORCE or LOAD} = 162 \times (2.7 - w) \times (l \times h) \times \text{DF} \times 9.8$$

Orientation — Face 6 Down:

$$\text{FORCE or LOAD} = 162 \times (2.7 - l) \times (w \times h) \times \text{DF} \times 9.8$$

Where:	FORCE = or LOAD =	Newtons of force (Nf) or Newtons (N)
	162 =	average density of LTL freight (kg/m ³)
	2.7 =	inside height of trailer (m), see Note 3
	h =	height of product(s) or shipping unit (m)
	l =	length of product(s) (m)
	w =	width of product(s) (m)
	DF =	Design Factor from Table 6
	9.8 =	metric conversion factor (m/s ²)

NOTE 3—If the package weighs less than 30 lbs (14 kg) or is 2 ft³ (0.056 m³) or less in size, the factor is reduced to 54 in (1.4 m) instead of 108 in (2.7 m).

Table 6: Design Factor

Shipping Unit Construction	Design Factor (DF)	
	Machine Compression	Dead Weight
	ASTM D642	ASTM D4577
(a) A corrugated fiberboard or plastic container that may or may not have stress-bearing interior packaging using these materials, and where the product does not support any of the load. An example is a plastic bottled product in a corrugated box with a corrugated interior packaging.	7.0, see Note 4	5.3, see Note 4
(b) A corrugated fiberboard or plastic container that has stress-bearing interior packaging with rigid inserts such as wood. An example is an appliance packed in a corrugated box with wood-reinforced corner posts.	4.5	3.4
(c) A container constructed of materials other than fiberboard or plastic that are not temperature or humidity sensitive or where the product supports the load directly. An example is a wood crate or box.	3.0	2.3

NOTE 4—When testing fiberboard containers that have been conditioned to 40°F (4°C) and 85% RH or 100°F (38°C) and 85% RH, the Design Factor should be reduced by 50%.

(Continued on following page)

RULES

ITEM 180-A-Continued

(2) **Vibration Testing:** Using the same shipping unit, conduct vibration testing on all three faces, except as noted below. Face 3 must be tested for one hour and Faces 4 and 6 must be tested for 30 minutes each, for a total duration of two hours, using any of the three following vibration methods, see Note 5:

- (a) Random Vibration, ASTM D4169 Schedule E ►(truck profile test);
- (b) Repetitive Shock, ASTM D4169 Schedule F (vertical-linear motion); or
- (c) Repetitive Shock, ASTM D4169 Schedule F (rotary motion).

If the shipping unit has a lift truck skid or pallet outside base, or is marked with upright arrow symbols, only Face 3 should be vibrated ► for two hours.

NOTE 5—For high or unstable shipping units, random or vertical-linear tests may be preferred.

Section III. Impact/Handling Test

Following compression/vibration tests, the same shipping units must be impact/handling tested using the following procedures:

Procedure (A)

For packages having no external attached or integral pallet or skid and not in a palletized load, perform an impact/handling test as follows, see Notes 6 and 7:

- (1) Under 200 lbs (91 kg) gross weight—perform a free-fall drop test in accordance with ASTM D5276, using the following height and sequence:

Table 7: Procedure (A) Drop Heights

For Shipping Weight, lbs (kg)	Drop Height, in (m)
Up to and including 40 (18)	24 (0.61)
41 (19) up to and including 80 (36)	18 (0.46)
81 (37) up to and including 100 (45)	12 (0.30)
101 (46) up to and including 199 (90)	10 (0.25)

- (a) Top;
- (b) A side (using the side most prone to damage, if known);
- (c) An adjacent side (using the adjacent side most prone to damage, if known);
- (d) A bottom corner (using bottom corner most prone to damage, if known);
- (e) A bottom edge radiating from the diagonally opposite bottom corner (using the edge most prone to damage, if known).
- (f) *The final drop must be on the bottom from a drop height at 1.5 times the specified height, where the bottom is defined as the surface upon which the package is most likely to rest during shipment (upright arrows also define the bottom for transport).*

NOTE 6—If a package with a long dimension begins to fall over after dropping on a corner or edge, do not catch or restrain the package. Let it fall over. However, if any package dimension is more than twice the drop height in its drop orientations, once dropped, the package may be prevented from tipping over.

NOTE 7—The package should be designed to withstand drops from the specified height from any drop orientation.

- (2) For 200 lbs (91 kg) gross weight and over—perform an incline impact or a pendulum impact test according to ASTM D880, or a horizontal impact on a test machine with short duration shock programmer (ASTM D4003), as follows:

- (a) Impact the top, two adjacent sides and bottom at a final minimum velocity of 5.75 ft/sec (1.75 m/sec); **OR**
- (b) Alternately, the impact test may be provided by free-fall from a drop height of 6.0 in (0.15 m) on the top, two adjacent sides and bottom.
- (c) Also conduct a rotational corner drop test (ASTM D6179) from a 6.0 in (0.15 m) height on a bottom corner and a rotational edge drop test on a bottom edge radiating from the diagonally opposite bottom corner.

Procedure (B)

For individual packages with external attached or integral pallets/skids, including crates, perform impact and handling tests as follows:

- (1) Based on the gross weight of the total load, perform a Rotational Flat Drop Test according to ASTM D6179 as follows:

Table 8: Procedure (B) Drop Heights

Weight, lbs (kg)	Drop Height, in (m)
Up to 500 (227)	12 (0.30)
500 (227) and over	9 (0.23)

(a) With one bottom handling edge of the shipping unit supported by the floor, raise the other end to prescribed height and release it to fall flat on the floor. Repeat the test by lifting and dropping opposite bottom edge of shipping unit from same height.

(b) When using the specified drop heights would result in an unstable (unsafe) condition, the greatest drop height consistent with safety should be used. The drop height should be carefully measured and recorded.

- (2) **Impact Test**—Perform an incline impact test or a pendulum impact test according to ASTM D880, or a horizontal impact on a test machine with short duration shock programmer (ASTM D4003), impacting each of the four sides at the final minimum velocity of 4.0 ft/sec (1.2 m/sec).

(Continued on following page)

RULES

ITEM 180-A-Continued

Procedure (C)

For palletized loads made up of a multiple number of containers or unitized loads of a bulk configuration, perform both impact tests in Procedure (B). In addition:

(1) Conduct a fork truck handling test according to ASTM D6055:

Pick up shipping unit with lift truck having 36 in (0.9 m) forks (for longer forks, penetrate pallet only 36 in (0.9 m)); transport around test course, and set down. Repeat the moves four more times for a total of five moves. The test course should include at least one right angle turn on a rigid flat surface representative of carrier terminals and warehouses. A modified 2 in x 6 in board with long edge beveled full height at 45 degrees (see diagram below) shall be placed on the course in a position where both lift truck wheels on one side must pass over it during each handling sequence, and a second modified 2 in x 6 in board shall be placed on the course after the right angle turn in such a position that both lift truck wheels on the opposite side must pass over it during each handling sequence. The speed of the truck passing over the 2 in x 6 in boards and rounding the right angle turn shall be at least 2 mph (3.2 km/hr). Vertical alignment of palletized containers must be reasonably maintained throughout the test.

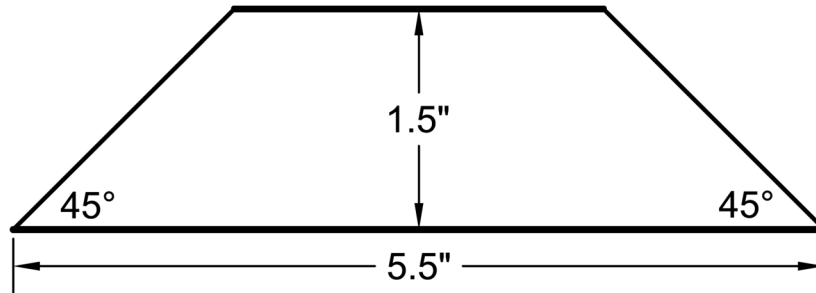

OR

(2) Conduct a repetitive shock test (Rotary Motion) in accordance with ASTM D999, Method 2A:

Unitized pallet load of individual cases on a pallet must be subject to 10 minutes each in the "X" and "Y" directions. Place the load on the repetitive (Rotary) vibration machine. Operate equipment at 30° out of phase between 165 and 200 rpm (180 rpm recommended) for duration of 10 minutes. Rotate 90° after 10 minutes and continue for the remainder of 10 minutes. Inspect for load containment and damage during and following testing.

Section IV. Concentrated Impacts

To accommodate the use of this rule for packages where wrapping materials such as stretch wrap, shrink wrap, or paper are used in lieu of rigid outside containers, in addition to meeting the applicable performance requirements of Sections II and III, wrapped packages must be tested in accordance with ASTM D6344 Standard Test Method for Concentrated Impacts to Transport Packages. All faces of the package must be tested where wrapping is the only material covering a portion of the face, unless that face is the bottom of a package with an integral handling platform. ►Each side of package must be impacted in the location most likely to cause damage to the product.

Section V. Documentation

Test methods, conditions, and results must be recorded on the following form and permanently held on file for the duration the article is subject to this rule. The name shown above the certification symbol (Section VII) shall be the contact for such documentation. Changes in product construction and/or material or packaging require subsequent testing and documentation. At a minimum, the report should include the following:

- (1) Shipper requesting tests (including contact name, address, phone number and email);
- (2) Description of article, including model number, size, weight and other distinguishing features;
- (3) Description of shipping unit, including specifications of container and interior packaging;
- (4) Testing performed;
- (5) Conditioning and test conditions;
- (6) Acceptance criteria;
- (7) Condition of specimens (article and packaging) after testing; and
- (8) Laboratory performing tests (including contact name, address, phone number and email)

RULES

**National Motor Freight Classification – Item 180
Package Performance Laboratory Test Report**

FCDC-Registered Testing Laboratory

Date:	Reference No.:
Lab:	Lab Technician:
Address:	Email:
City, State Zip:	Phone Number:
Country:	Signature:

Product / Package Information and Warehouse / Distribution Environment

I. Product Information (including product name and model number)

II. Package Information

- a. External container dimensions:
- b. Gross weight of packaged product:
- c. Sample size:
- d. Description of packaging and/or palletizing (including interior packing forms):

III. Warehouse / Distribution Environment

- | | | |
|-----------------------|-----|----|
| a. Clamp Lifts: | Yes | No |
| b. Basiloid Lifts: | Yes | No |
| c. Hanging Conveyors: | Yes | No |

Test Conditions and Procedure

IV. Description of Conditioning and Test Conditions

- a. Average temperature:
- b. Average relative humidity:
- c. Length of time under conditions:

V. Testing Performed (detailed description of test equipment used and test method followed)

- a. Compression / Vibration Testing
 - i. Method (A)
 - ii. Method (B)
- b. Impact / Handling Testing
 - i. Procedure (A)
 - ii. Procedure (B)
 - iii. Procedure (C)
- c. Concentrated Impact Testing

VI. Acceptance Criteria (full description of the test pass / fail criteria)

VII. Results of Test (condition of specimen after testing)

VIII. Attach photos of test specimen before and after testing.

Shipper / Manufacturer

Company Name:	Contact Name:
Address:	Email:
City, State Zip:	Phone Number:
Country:	Registration Number:

RULES

ITEM 180-A-Continued

Section VI. Acceptance Criteria

- (1) The shipping unit shall be deemed acceptable after performance testing if the following criteria are met:
- The article is neither damaged nor nonfunctional.
 - The shipping unit has maintained its integrity and still affords reasonable protection against the normal rigors of transportation.
- (2) The acceptance criteria of article damage and nonfunctionality must be predetermined before testing and included in the report.

Section VII. Certification

(1) Packages tested in accordance with this rule and certified as such by the Freight Classification Development Council's (FCDC's) Packaging Consultant must conspicuously bear the following triangular symbol that is 3 in wide at the top and 3.75 in high, showing that they meet the minimum performance requirements specified. This marking is the responsibility of the shipper or testing laboratory as identified above the symbol by name, city and state. Testing must be conducted by a testing laboratory that is registered with the FCDC, see Note 9.

(2) Directly above each certification symbol there must be printed a FCDC Performance Test Registration Number. Such number will be issued on an annual basis by the FCDC upon receipt of a properly completed form requesting such a Registration Number, signed by the FCDC's Packaging Consultant or other FCDC member and certifying that the symbol and Registration Number will be imprinted only on those packages which have met the minimum performance test requirements specified. Further, the applicant must divulge on the form the location or locations where completed test report forms are available for inspection upon reasonable request.

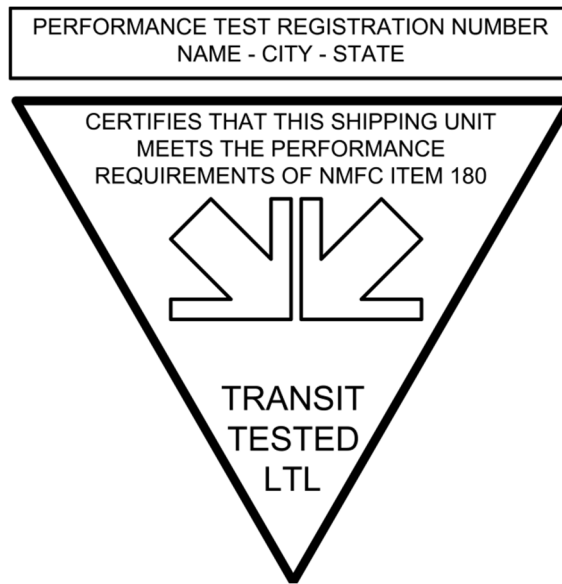

(a) In the event of a damage claim, carriers may request a retest at a different FCDC-registered laboratory (see Note 9). The retest must be conducted according to the same test plan as was used for the certification testing; no alternative procedures or types of test equipment may be substituted. Should the shipping unit fail the retest, a second retest of two shipping units may be conducted at the second laboratory and both shipping units must pass the retest.

(b) All shipping unit configurations and article sizes and variations must be tested and new reports filed for the purpose of certification by this rule (see Note 8). Any time a packaging or product change is made, the required performance tests must be repeated.

(c) When minor variations are made in articles, a single test sequence may be performed for certification, provided the variations have no effect on the degree of protective packaging required. Examples of minor variations may be color differences, electrical voltage/wiring, or left hand/right hand.

NOTE 8—When the shipping unit certified is a palletized load or a unitized load, the packaged products in the load are not certified as individual shipping units unless they are also successfully tested as individual packages and are so certified. Such palletized or unitized loads must show the triangular certification symbol on an upper position of not less than one sidewall.

NOTE 9—To qualify as a third party laboratory, the facility must register on an annual basis with the FCDC. A list of registered third party laboratories is provided in Item 183. For the most up-to-date list of registered labs, please refer to the FCDC's website, www.nmfta.org. Shippers with in-house laboratories that test their own products must also register on an annual basis with the FCDC.

ITEM 181-A

FURNITURE PACKAGE PERFORMANCE TESTING

► This rule provides an alternative to Item 180, packaging provisions as found within the Furniture Group (item 79000), and the Numbered Packages. It is recommended for solving chronic damage problems and for providing an acceptable assurance level of packaging for articles of furniture. This test procedure is to represent normal handling and distribution of boxed furniture or furniture parts. This rule does not purport to address all of the safety issues, if any, associated with its use. It is the responsibility of the user of this rule to establish appropriate safety and health practices.

This test procedure does not apply to packages utilizing stretch or shrink plastic film wrap-style shipping units. This procedure applies only to furniture that is fully contained within corrugated fiberboard shipping containers. Exceptions include corrugated fiberboard flanged, open-bottom containers only when the container is appropriately marked with UP arrows. Furniture tendered in a corrugated fiberboard container secured on a lift truck skid or pallet, or with a lift truck skid or pallet base, should be tested under Item 180.

In order to qualify as authorized methods of packaging under this rule, shipping containers must be preshipment tested and successfully pass the following prescribed performance test requirements and must meet the acceptance criteria as indicated.

Shippers will be required to perform the following specified minimum tests to be considered as an approved package and be eligible to certify shipping containers as specified within Section VI herein. Multiple test specimens are recommended when available, and all specimens tested must pass.

RULES

ITEM 181-A-Continued

For the purpose of retest uniformity, handling steps utilized in transporting the article (once fully packaged) from the production line to the warehouse to the testing laboratory, i.e., clamp trucks, baseloid lift trucks, hanging conveyors, must be identified and documented on test report form so that these procedures may be repeatable.

Orientation and Nomenclature for Test Specimens: Place the container in its normal shipping orientation with the front facing forward and then proceed with marking the faces according to the diagram shown below. Note the Manufacturer's Joint, when present, may or may not be located in the same position as shown in the diagram.

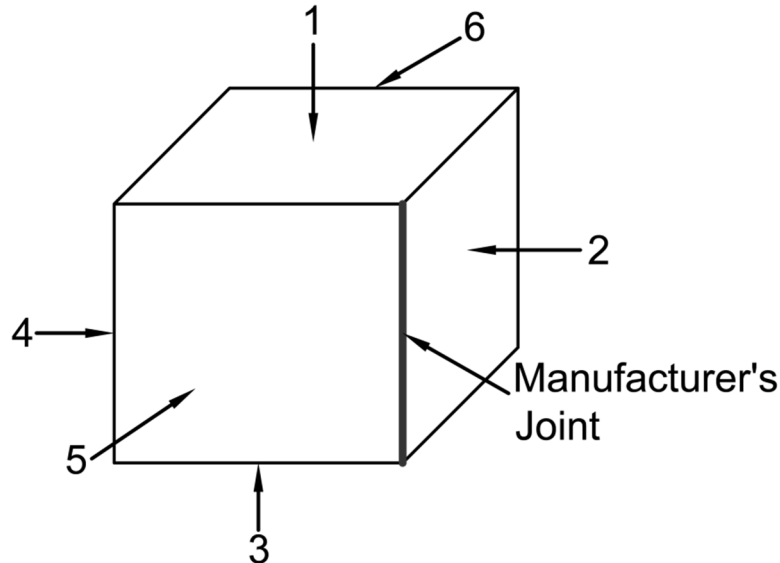

PERFORMANCE TEST REQUIREMENTS: All applicable shipping units must be tested as follows:

Section I. Conditioning

Except as provided in Note 1, all specimens must be conditioned in an atmosphere of 73°F (23°C) minimum and 50% RH minimum for at least 24 hours. Testing should be conducted in the same minimum atmosphere, and conditions must be recorded for each test conducted. If testing cannot be conducted in the minimum atmosphere, conduct the tests as soon as possible after the packaged products have been stored for 24 hours in the testing environment.

NOTE 1—Alternatively, fiberboard packaging may be conditioned in an atmosphere of 40°F (4°C) and 85% RH or 100°F (38°C) and 85% RH for at least 72 hours.

Section II. Compression/Vibration Test

Two alternate methods of testing are permissible: Method (A)—Stacked Compressive Load/Vibration Testing, or Method (B)—Separate Compressive Load/Vibration Testing. Either may be utilized, depending on test capability or product characteristics. Unless the shipping container is marked with upright arrow symbols, the container must be tested on Faces 3, 4 and 6. If the shipping unit is marked with upright arrow symbols, the compressive load or force requirements in Methods (A) and (B) for Faces 4 and 6 may be omitted.

Method (A)—Stacked Compressive Load/Vibration Testing

Shipping units must be vibration tested under a stacked compressive load using either an identical shipping unit, or a concentrated dead weight load as described below.

(1) **Calculating Concentrated Dead Weight Loads:** When conducting concentrated dead weight load vibration tests, the size of the package changes with the three shipping orientations of the package, and the concentrated dead load weights on the top of the package will change accordingly. Use a concentrated dead load (see Description of Load Apparatus in Paragraph (2)(a) below) to simulate miscellaneous freight loaded on top of a floor-stowed shipping unit in a trailer. Determine the required loads, rounded up to the nearest 5 pounds (lbs), from the formulas in Table 1 or 2. See Notes 2 and 3.

(Continued on following page)

RULES

ITEM 181-A-Continued

Table 1: Method (A) Load Calculation

Orientation — Face 3 Down:

$$\text{LOAD} = \frac{10 \times (108 - h) \times (l \times w)}{1728}$$

Orientation — Face 4 Down:

$$\text{LOAD} = \frac{10 \times (108 - w) \times (l \times h)}{1728}$$

Orientation — Face 6 Down:

$$\text{LOAD} = \frac{10 \times (108 - l) \times (w \times h)}{1728}$$

Where:	LOAD =	pounds (lbs)
	10 =	average density of LTL freight (pcf)
	108 =	inside height of trailer (in)
	1728 =	conversion factor (in ³ /ft ³)
	h =	height of shipping unit (in)
	l =	length of shipping unit (in)
	w =	width of shipping unit (in)

Table 2: Method (A) Load Calculation (Metric)

Orientation — Face 3 Down:

$$\text{LOAD} = 162 \times (2.7 - h) \times (l \times w) \times 9.8$$

Orientation — Face 4 Down:

$$\text{LOAD} = 162 \times (2.7 - w) \times (l \times h) \times 9.8$$

Orientation — Face 6 Down:

$$\text{LOAD} = 162 \times (2.7 - l) \times (w \times h) \times 9.8$$

Where:	LOAD =	kilograms (kg)
	162 =	average density of LTL freight (kg/m ³)
	2.7 =	inside height of trailer (m)
	h =	height of shipping unit (m)
	l =	length of shipping unit (m)
	w =	width of shipping unit (m)
	9.8 =	metric conversion factor (m/s ²)

NOTE 2—To avoid any gross distortion of calculated loads, a maximum dead load of 750 lbs (340 kg) should be utilized when the calculated dead load exceeds this limitation.

NOTE 3—For step or form-fitting containers, the load may be applied proportionately, dividing the total load by the surface area of the panels formed by stepping.

(2)(a) **Description of Load Apparatus:** The concentrated dead load shall consist of the following: corrugated trays or HSC-style container(s) of doublewall construction having a corrugated medium maximum basis weight of 33 lbs (15 kg); a plywood sheet with a minimum thickness of 0.5 in (13 mm) resting inside the container on the complete area of the bottom inner flaps of the container; and a block of lead or sand contained in plastic bag(s) evenly distributed over the bottom surface of the container to complete the required calculated load (sand weighs approximately 110 pcf (50 kg/m³)). The dead load container(s) must be larger than the test specimen, but must not overhang the specimen by more than 1.5 in (38 mm). The dead load container(s) must be affixed so that it cannot move inside the perimeter of the test specimen during testing. The test specimen should not be fastened to the vibration table and should be allowed some lateral movement, yet restricted so that it does not move from under the perimeter of the dead load.

(Continued on following page)

RULES

ITEM 181-A-Continued

(2)(b) When test units have large top surfaces, i.e., any dimension exceeding 18 in (0.46 m), the dead load must be subdivided into smaller portions. If only one dimension exceeds 18 in (0.46 m), the load must be divided into two equal portions along the longer dimension. If both dimensions exceed 18 in (0.46 m), the load must be divided into four equal portions, as shown in the diagram below.

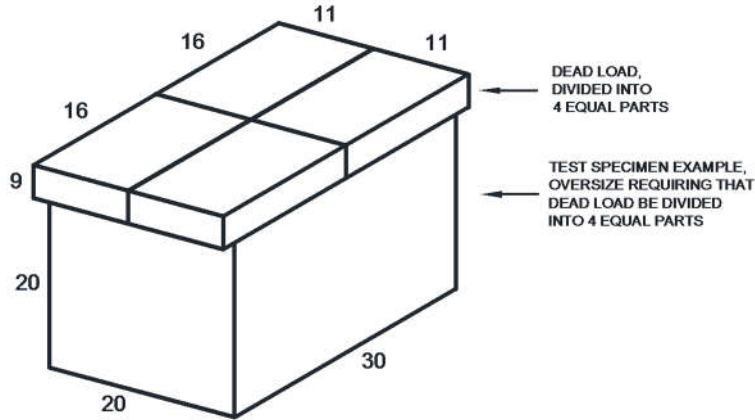

EXAMPLE OF CONCENTRATED DEAD LOAD ON TEST SPECIMEN FOR RANDOM VIBRATION TEST

TEST SPECIMEN SHOWN IN EXAMPLE MEASURES 30" X 20" X 20", LARGER THAN 18" IN BOTH LENGTH AND WIDTH, REQUIRING THAT THE DEAD LOAD BE DIVIDED INTO 4 EQUAL PARTS.

(3) **Vibration Testing:** Properly position either the identical shipping unit or the concentrated dead weight load on the shipping unit. Using procedure ASTM D4169 Schedule D, Truck Profile, Assurance Level II, for random vibration load, or procedure ASTM D4169 Schedule F for vertical-linear vibration under a stacked compressive load, test the shipping unit. Conduct the vibration testing on all three faces, except as noted below. Face 3 must be tested for one hour and Faces 4 and 6 must be tested for 30 minutes each, for a total duration of two hours. If the shipping unit is marked with upright arrow symbols, only Face 3 must be vibrated under the compressive load for two hours.

Method (B)—Separate Compressive Load/Vibration Testing

Shipping units must be subjected to compression and vibration in separate tests. The compression test is conducted first and then the same shipping unit is vibration tested.

(1) **Compression Testing:** Except as noted below, compression testing is required to be conducted on Faces 3, 4 and 6 of the same shipping unit, using either a machine compression test (per ASTM D642) or a constant load (dead weight) test (per ASTM D4577), see Table 3. When conducting compression tests, the size of the package changes with the three shipping orientations of the package, so the required concentrated forces or dead loads on the top of the package will change accordingly. Using the formulas below in Table 4 or 5, calculate the required force or load, depending upon which compression method is used, for each of the three faces, rounded up to the nearest 5 pounds force (lbf) or pounds (lbs), respectively. Apply the required compressive force or load on the shipping unit depending upon selected method found in Table 3. If the shipping container is marked with upright arrow symbols, only Face 3 should be compressed.

Table 3: Compression Method

Compression Type	Length of Compression Time	Compression Value Designation	Design Factor (DF)
Machine Compression Test per ASTM D642	Remove immediately once required force is reached	FORCE	7
Constant Load (Dead Weight) Test per ASTM D4577	1 hour/face	LOAD	5

(Continued on following page)

RULES

ITEM 181-A-Continued

Table 4: Method (B) Force or Load Calculation

Orientation — Face 3 Down:

$$\text{FORCE or LOAD} = \frac{10 \times (108 - h) \times (l \times w) \times \text{DF}}{1728}$$

Orientation — Face 4 Down:

$$\text{FORCE or LOAD} = \frac{10 \times (108 - w) \times (l \times h) \times \text{DF}}{1728}$$

Orientation — Face 6 Down:

$$\text{FORCE or LOAD} = \frac{10 \times (108 - l) \times (w \times h) \times \text{DF}}{1728}$$

Where:	FORCE = or LOAD =	pounds force (lbf) or pounds (lbs)
	10 =	average density of LTL freight (pcf)
	108 =	inside height of trailer (in)
	1728 =	conversion factor (in ³ /ft ³)
	h =	height of shipping unit (in)
	l =	length of shipping unit (in)
	w =	width of shipping unit (in)
	DF =	Design Factor from Table 3

Table 5: Method (B) Force or Load Calculation (Metric)

Orientation — Face 3 Down:

$$\text{FORCE or LOAD} = 162 \times (2.7 - h) \times (l \times w) \times \text{DF} \times 9.8$$

Orientation — Face 4 Down:

$$\text{FORCE or LOAD} = 162 \times (2.7 - w) \times (l \times h) \times \text{DF} \times 9.8$$

Orientation — Face 6 Down:

$$\text{FORCE or LOAD} = 162 \times (2.7 - l) \times (w \times h) \times \text{DF} \times 9.8$$

Where:	FORCE = or LOAD =	Newtons of force (Nf) or Newtons (N)
	162 =	average density of LTL freight (kg/m ³)
	2.7 =	inside height of trailer (m)
	h =	height of shipping unit (m)
	l =	length of shipping unit (m)
	w =	width of shipping unit (m)
	DF =	Design Factor from Table 3
	9.8 =	metric conversion factor (m/s ²)

NOTE 4—To avoid any gross distortion of calculated loads, a maximum dead load of 750 lbs (340 kg) should be utilized when the calculated dead load exceeds this limitation.

NOTE 5—For step or form-fitting containers, the load may be applied proportionately, dividing the total load by the surface area of the panels formed by stepping.

(2) **Vibration Testing:** Using the same shipping unit, conduct vibration testing on all three faces, except as noted below. Face 3 must be tested for one hour and Faces 4 and 6 must be tested for 30 minutes each, for a total duration of two hours, using any of the three following vibration methods:

- (a) Random Vibration, ASTM D4169 Schedule E, Truck Profile, Assurance Level II;
- (b) Repetitive Shock, ASTM D4169 Schedule F (vertical-linear motion); or
- (c) Repetitive Shock, ASTM D4169 Schedule F (rotary motion).

If the shipping unit is marked with upright arrow symbols, only Face 3 should be vibrated for two hours.

Section III. Impact/Handling Tests

Following compression/vibration tests, the same shipping units must be impact/handling tested using one of the following procedures:

(Continued on following page)

RULES

ITEM 181-A-Continued

Procedure (A)

Under 150 lbs AND under 130 united inches, from the formula of $(2 \times l) + (2 \times w) + h$, perform a free-fall drop test on six faces, three edges, and one corner using the heights in Table 6 and sequence in Table 7:

Table 6: Procedure (A) Drop Heights

Shipping Weight, lbs (kg)	Drop Height, in (cm)
0 – 25 (0 – 11)	30 (76)
Over 25 – 40 (Over 11 – 18)	24 (61)
Over 40 – 80 (Over 18 – 36)	18 (46)
Over 80 – 100 (Over 36 – 45)	12 (31)
Over 100 – 150 (Over 45 – 68)	10 (25)

Table 7: Procedure (A) Drop Sequence

Sequence #	Orientation	Specific face, edge or corner
1	Corner	Most fragile face-3 corner, if not known, test 2-3-5
2	Edge	Shortest edge radiating from the corner tested
3	Edge	Next shortest edge radiating from the corner tested
4	Edge	Longest edge radiating from the corner tested
5	Face	One of the smallest faces
6	Face	Opposite small face
7	Face	One of the medium faces
8	Face	Opposite medium face
9	Face	One of the largest faces
10	Face	Opposite large face

Procedure (B)

Perform tests as described in sections (1) AND (2) below:

(1) For 150 lbs or greater AND/OR 130 united inches or greater from the formula of $(2 \times l) + (2 \times w) + h$:

(a) Perform an incline impact test according to ASTM D880, or a horizontal impact on a test machine with short duration shock programmer (ASTM D4003). Impact velocity of 5.75 ft/sec (1.75 m/sec), using the sequence in Table 8.

Table 8: Procedure (B) Impact Sequence

Sequence	Location of Impact
1	One of the smallest faces
2	Opposite small face
3	One of the medium faces
4	Opposite medium face
5	One of the largest faces
6	Opposite large face

OR

(b) Perform a free-fall drop height of 6 in (0.15 m) on the top (face 1), two adjacent sides (faces 2 and 5), and the bottom (face 3) of shipping container for a total of four drops.

(2) In addition, when the shipping container length dimension is greater than the height dimension, conduct an 8 in (0.20 m) rotational edge drop in accordance with ASTM D6179-9.1 on the following four edges formed by faces: 4 and 5, 2 and 5, 4 and 6, and finally 2 and 6 for a total of four drops. If the shipping container height dimension is greater than the length dimension, perform test on the following four edges formed by faces: 3 and 6, 3 and 5, 1 and 5, and finally 1 and 6.

Section IV. Documentation

Test methods, conditions, and results must be recorded on the following form and permanently held on file for the duration the article is subject to this rule. The name shown in the certification symbol, displayed in Section VI of this rule, shall be the contact for such documentation. Changes in product construction and/or material or packaging require subsequent testing and documentation. At a minimum, the report should include the following:

- (1) Shipper requesting tests (including contact name, address, phone number and email);
- (2) Description of article, including model number, size, weight and other distinguishing features;
- (3) Description of shipping unit, including specifications of container and interior packaging;
- (4) Testing performed;
- (5) Conditioning and test conditions;
- (6) Acceptance criteria;
- (7) Condition of specimens (article and packaging) after testing; and
- (8) Laboratory performing tests (including contact name, address, phone number and email)

RULES

Section V. Acceptance Criteria

- (1) The shipping unit shall be deemed acceptable after performance testing if the following criteria are met:
 - (a) The article is neither damaged nor nonfunctional.
 - (b) The shipping unit has maintained its integrity and still affords reasonable protection against the normal rigors of transportation.
- (2) The acceptance criteria of article damage and nonfunctionality must be predetermined before testing and included in the report.

Section VI. Certification

(1) Packages tested in accordance with this rule and certified as such by the Freight Classification Development Council's (FCDC's) Packaging Consultant must conspicuously bear the following octagonal symbol that is 3 in by 3 in showing that they meet the minimum performance requirements specified, see Note 6. This marking is the responsibility of the shipper or FCDC-registered testing laboratory, identified within the symbol by name, city and state. Testing must be conducted by the shipper on their own products or by any FCDC-registered testing laboratory, see Note 7.

(2) Directly above each certification symbol there must be printed a FCDC Performance Test Registration Number. Such number will be issued on an annual basis by the FCDC upon receipt of a properly completed form requesting such a Registration Number, signed by the FCDC's Packaging Consultant or other FCDC member and certifying that the symbol and Registration Number will be imprinted only on those packages which have met the minimum performance test requirements specified. Further, the applicant must divulge on the form the location or locations where completed test report forms are available for inspection upon reasonable request.

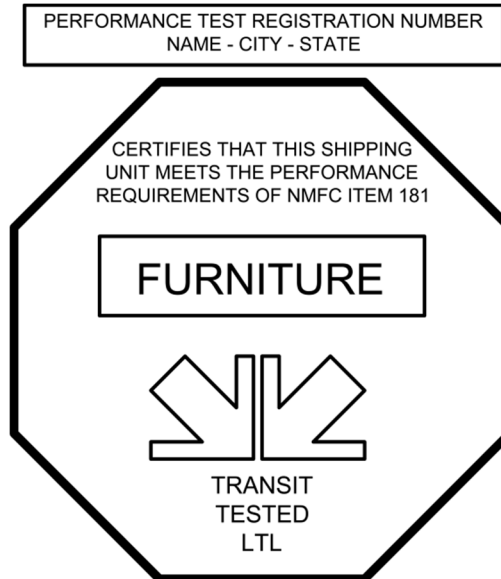

NOTE 6—The use of the above certification symbol does not negate container marking required in Note, item 79022, paragraph (c).

(3) In the event of repeated damages, carriers may request a retest at a FCDC-registered laboratory. The retest must be conducted according to the same test plan as used for the initial certification testing. No alternative procedures or types of test equipment may be substituted. Should the shipping unit fail the retest, a second retest of two shipping units may be conducted at a FCDC-registered laboratory and both shipping units must pass the retest.

NOTE 7—To qualify as a third party laboratory, the facility must register on an annual basis with the FCDC. A list of registered third party laboratories is provided in Item 183. For the most up-to-date list of registered labs, please refer to the FCDC's website, www.nmfta.org. Shippers with in-house laboratories that test their own products must also register on an annual basis with the FCDC.

RULES

ITEM 183-B

FCDC-REGISTERED THIRD PARTY PACKAGE TESTING LABORATORIES

The package testing laboratories named below are registered with the Freight Classification Development Council and are qualified to conduct the performance test procedures detailed in Items 180 and 181. For the most up-to-date list of registered labs, please refer to the FCDC's website, www.nmfta.org/pages/FCDCRegistered.

Laboratory	Location	Contact	Phone Number
Advanced Packaging Technology Laboratories, Inc.	Wheeling, IL	Monica White	847.520.4343
ANAMA Package & Container Testing Services, Inc.	Stamford, CT	Anton Cotaj	203.658.8490
Bureau Veritas Consumer Products Services Vietnam	Ho Chi Minh City, Vietnam	Ryan Nguyen	84.966.357953
China Packaging Research & Test Center	Tianjin, China	Wang Qing	86.22.66237185
FedEx Packaging Lab	Collierville, TN	Evan Edwards	901.850.3597
Intertek Testing Service Shenzhen Limited, Guangzhou Branch	Guangzhou, Guangdong, China	Bo Wang	86.20.82139764
Intertek Testing Services Shenzhen Ltd.	Shenzhen, Guangdong, China	Frank Liao	86.755.2602.0374
Keystone Package Testing	New Castle, PA	Scott Bischoff	724.698.2994
★Multi-Wall Packaging Corp.	Danville, VA	Rob Reynolds	434.836.7802
Outlook Technical Services (Vietnam) Ltd.	Di An City, Binh Duong Province, Vietnam	Christine Nguyen	84.774.356.503
Packaging Corporation of America	Mundelein, IL	Brandon Hink	847.388.6034
Performance Testing Laboratories, LLC	Orange, CA	Mary Beth Proctor	714.957.9300
Pro-Pack Testing Laboratory, Inc.	Belleville, IL	Manuel Rosa, Jr.	618.277.1160
PT. Outlook Technical Service	Sidoarjo, Jawa Timur, Indonesia	Daud Musafar	62.31.891.7907
SGS-CSTC Standards Technical Services Co., Ltd. Shunde Branch	Shunde, Foshan, Guangdong, China	Heather Meng	86.757.2280.5851
WestRock	Carol Stream, IL	Jim Rivera	630.384.5237

SUPPLEMENT 2 TO NMF 100-AW

ITEM	ARTICLE	CLASS
4605-A	ADHESIVES GROUP: ...☒Cancel; no further application.	
4615-A	Adhesives , hot melt, in rolled sheets, etc...☒Cancel; see item 4625.	
4620-A	Adhesives, NOI, Adhesive Cements, NOI, Adhesive Glues, NOI, or Adhesive Pastes, NOI , not required by the U.S. Department of Transportation to bear a Hazard Class or Hazard Division label or placard, see Notes, items 4621 and 4622, etc...☒Cancel; see item 4625.	
4621-A	NOTE—☒Cancel; see item 4626.	
4622-A	NOTE—☒Cancel; no further application.	
★4625	Adhesives, NOI, Adhesive Cements, NOI, Adhesive Glues, NOI, or Adhesive Pastes, NOI , not required by the U.S. Department of Transportation to bear a Hazard Class or Hazard Division label or placard, see Note, item 4626, in bags, boxes, drums, pails, intermediate bulk containers (IBCs), portable tanks or Packages 1398, 2213, 2399, 2440, 2445, 2452, 2458, 2463, 2467, 2478, 2496, 2499, 2500, 2515, 2516, 2521, 2526, 2528 or 2530, subject to Item 170 and having a density in pounds per cubic foot of:	
Sub 1	Less than 15	100
Sub 2	15 but less than 22.5	70
Sub 3	22.5 but less than 30	65
Sub 4	30 or greater	55
★4626	NOTE—Does not apply on materials regulated by the U.S. Department of Transportation as hazardous and required to bear a Hazard Class or Hazard Division label or placard. For classes applicable to such hazardous materials, see provisions elsewhere in this Classification.	
4630-A	Adhesives or Epoxy Resins , electrically conductive, containing gold or silver, see Notes, items 4631 and 4632, etc...☒Cancel; obsolete.	
4631-A	NOTE—☒Cancel; no further application.	
4632-A	NOTE—☒Cancel; no further application.	
4633-A	NOTE—☒Cancel; no further application.	
4635-A	Adhesives , synthetic resin, consisting of paper coated or impregnated with synthetic resin adhesive, etc...☒Cancel; see item 4625.	
4637-A	Glue , casein, dry, etc...☒Cancel; see item 4625.	
	ATHLETIC GOODS GROUP: subject to item 15500	
15505-A	Apparatus , exercising, tubular metal frame with cloth or fabric body support or sling, etc...☒Cancel; see item 15520.	
▶15520-A	Athletic or Sporting Goods, viz.: Athletic or Sporting Goods or Equipment, NOI; Balls, sports, NOI, see Note, item 15526; Basketball Nets, Rims or Backboards; Batons, twirling; Bats, Clubs, Rackets or Sticks, sports; Blinds, hunters', with or without accessories and camouflage materials; Boards, water sports, NOI, see Notes, items 15523 and 15524; Bowling Balls or Pins, NOI; Boxes, Buckets, Cages, Canteens, Containers or Pails, live bait; Decoys, bird, NOI; Exercising or Gymnasium Apparatus or Equipment, NOI; Fish Bait, shelf-stable; Fishing Tackle, NOI; Floats, Rafts or Toys, water sports, NOI, see Note, item 15524; Gloves or Mitts, baseball, softball or boxing; Golf Mats or Platforms, NOI, with or without tees; Masks, sports; Nets, sports, NOI; Playground Apparatus, NOI, see Note, item 15525; Pools or Pool Kits, swimming or wading, above-ground or semi-inground, see Note, item 15527; or Parts thereof, NOI; Rifles or Pistols, air or gas powered, NOI, including BB Guns; Sandboxes; Skateboards, see Note, item 15528; Skates, ice or roller, including In-Line Skates; Skis, snow or water, NOI; Snowboards or Snowboard Bindings; Snowshoes; Swimming Fins, Goggles, Masks, Nose Clips or Snorkels; Tows (Ropes), water skiing; Weight Lifting Benches or Athletic Utility Benches, NOI; In boxes or crates, see Note, item 15522, subject to Item 170 and having a density in pounds per cubic foot of:	
Sub 1	Less than 1	400
Sub 2	1 but less than 2	300
Sub 3	2 but less than 4	250
Sub 4	4 but less than 6	175
Sub 5	6 but less than 8	125
Sub 6	8 but less than 10	100
Sub 7	10 but less than 12	92.5
Sub 8	12 but less than 15	85
Sub 9	15 but less than 22.5	70
Sub 10	22.5 but less than 30	65
Sub 11	30 or greater	60

ITEM	ARTICLE	CLASS
	ATHLETIC GOODS GROUP: subject to item 15500	
△15522-A	NOTE—The following departures from packing requirements are permitted: 1. Playground apparatus may be shipped in packages. 2. Molded plastic sandboxes or wading pools may be shipped in woven plastic film bags of not less than 4 mil thickness. 3. Motorized exercise treadmills may be shipped in Package 2484. 4. Not currently used. 5. Trampolines, KD, may be shipped in packages.	
△15523-A	NOTE—Applies on products such as Bodyboards, Kickboards, Kneeboards, Paddleboards, Sailboards , with or without sails, or Surfboards , not exceeding 96 inches in greatest dimension. For provisions applicable to articles exceeding 96 inches in greatest dimension, see item 24670.	
△15524-A	NOTE—Applies on articles used by children or adults for play, instruction or safety.	
△15525-A	NOTE—Does not apply on inflatable or air-supported enclosures, structures or promotional or advertising figures or images, nor on amusements, such as games, bouncers, rides or slides for use at outdoor picnics, birthday parties, fund-raising or promotional events or other such festivities. For applicable provisions, see item 63595.	
★15526	NOTE—Applies only on balls of official or regulation size and weight. Balls that do not meet these specifications are classified as play balls, per item 84260.	
★15527	NOTE—Also applies on accompanying complement of accessories or equipment.	
★15528	NOTE—Does not apply on motorized skateboards. For applicable provisions, see item 190235.	
15530-A	Backboards , basketball goal, with or without mounting hardware, etc...☒Cancel; see item 15520.	
15535-A	Bait , fish, natural, preserved; dough or meal type; coagulated or congealed blood type; preserved pork rind type; or salmon egg, etc...☒Cancel; see item 15520.	
15540-A	Balls , croquet, composition, etc...☒Cancel; see item 15520.	
15545-A	Balls , hand or squash, rubber, hollow, etc...☒Cancel; see item 15520.	
15560-A	Balls , NOI, inflated, with or without final cover, see Note, item 15562, etc...☒Cancel; see item 15520.	
15562-A	NOTE—☒Cancel; see item 15526.	
15580-A	Balls , table tennis (Ping-Pong Balls), etc...☒Cancel; see item 15520.	
15590-A	Balls , tennis, etc...☒Cancel; see item 15520.	
15600-A	Baseballs , finished, etc...☒Cancel; see item 15520.	
15620-A	Bases , baseball or softball, or Plates , home or pitchers', etc...☒Cancel; see item 15520.	
15640-A	Batons , twirling, with or without rubber fittings or decorations, etc...☒Cancel; see item 15520.	
15680-A	Bats , baseball, softball or cricket, other than hollow plastic, etc...☒Cancel; see item 15520.	
15820-A	Bindings , alpine snow ski, metal or metal and plastic combined, etc...☒Cancel; see item 15520.	
15930-A	Bowling Balls , other than hollow molded plastic, NOI, etc...☒Cancel; see item 15520.	
15940-A	Bowling Pins , other than hollow molded plastic, etc...☒Cancel; see item 15520.	
16040-A	Croquet Sets , with solid mallet heads, handles and balls, etc...☒Cancel; see item 15520.	
16060-A	Curling Stones , etc...☒Cancel; see item 15520.	
16080-A	Cushions , toboggan, etc...☒Cancel; see item 15520.	
16100-A	Decoys , bird, mechanical, with or without batteries, etc...☒Cancel; see item 15520.	
16160-A	Discs , shuffleboard, composition or rubber, etc...☒Cancel; see item 15520.	
16190-A	Dumbbells or Barbells ; iron; or iron and plastic combined, cement-filled, etc...☒Cancel; see item 15520.	
16192-A	NOTE—☒Cancel; no further application.	
16200-A	Dumbbells , metal, NOI, etc...☒Cancel; see item 15520.	
16255-A	Fish Hooks , etc...☒Cancel; see item 15520.	
16260-A	Fish Stringers , etc...☒Cancel; see item 15520.	
16270-A	Fishing Line , etc...☒Cancel; see item 15520.	
16280-A	Fishing Poles or Rods , see Note, item 16281, etc...☒Cancel; see item 15520.	
16281-A	NOTE—☒Cancel; no further application.	
16320-A	Football Blocking Dummies , etc...☒Cancel; see item 15520.	
16330-A	Football Blocking Machines or Sleds , etc...☒Cancel; see item 15520.	
16332-A	NOTE—☒Cancel; no further application.	
16420-A	Gloves , baseball or boxing, etc...☒Cancel; see item 15520.	
16430-A	Goals , basketball, steel, with or without nets or mounting hardware, etc...☒Cancel; see item 15520.	
16440-A	Golf Balls , etc...☒Cancel; see item 15520.	
16490-A	Golf Club Bags , etc...☒Cancel; see item 187645.	
16520-A	Golf Club Shafts , unfinished, etc...☒Cancel; see item 15520.	
16530-A	Golf Clubs, or Parts thereof , NOI, finished, etc...☒Cancel; see item 15520.	
16550-A	Golf Practice Tees or Platforms , mechanical...☒Cancel; see item 15520.	
16620-A	Hockey Pucks , etc...☒Cancel; see item 15520.	
16630-A	Hockey or Shinney Sticks , etc...☒Cancel; see item 15520.	
16650-A	Hooks , gaff, steel, with wooden handles, etc...☒Cancel; see item 15520.	
16660-A	Horseshoe Pitching Pegs or Stakes, or Pitching Horseshoes , etc...☒Cancel; see item 15520.	
16810-A	Markers , swimming pool lane, plastic, with steel cable, with or without fittings necessary for installation, etc...☒Cancel; see item 15520.	
16820-A	Masks , baseball or fencing, etc...☒Cancel; see item 15520.	
16835-A	Mats, Cushions or Pads , exercise, gymnastic or jumping pit, see Note, item 16836, etc...☒Cancel; see item 149265.	
16836-A	NOTE—☒Cancel; no further application.	
16950-A	Nets , tennis, etc...☒Cancel; see item 15520.	
16985-A	Points , archery arrow, target screw-type, steel, with or without aluminum arrow shaft inserts, etc...☒Cancel; see item 15520.	
17040-A	Polo Balls , wooden, etc...☒Cancel; see item 15520.	
17050-A	Pools or Pool Kits , swimming or wading, above-ground or semi-inground, see Note, item 17051, or Parts thereof , NOI, etc...☒Cancel; see item 15520.	
17051-A	NOTE—☒Cancel; see item 15527.	

ITEM	ARTICLE	CLASS
	ATHLETIC GOODS GROUP: subject to item 15500	
17056-A	Posts , tennis, etc...☒Cancel; see item 15520.	
17060-A	Quoits , etc...☒Cancel; see item 15520.	
17100-A	Rifles or Pistols , air, spring-powered (B-B Guns), see Note, item 17101, etc...☒Cancel; see item 15520.	
17101-A	NOTE—☒Cancel; no further application.	
17110-A	Rifles or Pistols , air or gas powered, NOI, etc...☒Cancel; see item 15520.	
17160-A	Sandboxes , children's playground, NOI, see Note, item 17162, etc...☒Cancel; see item 15520.	
17162-A	NOTE—☒Cancel; no further application.	
17200-A	Saucers or Discs , throwing or hovering, plastic, other than expanded, see Note, item 17201, etc...☒Cancel; see item 15520.	
17201-A	NOTE—☒Cancel; no further application.	
17260-A	Shuttlecocks , badminton, etc...☒Cancel; see item 15520.	
17290-A	Sinkers , lead, etc...☒Cancel; see item 15520.	
17300-A	Skateboards , with wheels attached, without posts or standards, see Note, item 17301, etc...☒Cancel; see item 15520.	
17301-A	NOTE—☒Cancel; see item 15528.	
17310-A	Skates , ice or roller, including In-Line Skates , etc...☒Cancel; see item 15520.	
17330-A	Skis , snow, cross-country (Nordic-type Snow Skis); Skis , NOI; or Ski Poles , etc...☒Cancel; see item 15520.	
17335-A	Skis , snow, downhill (Alpine-type Snow Skis), etc...☒Cancel; see item 15520.	
17340-A	Skis , water, other than power, etc...☒Cancel; see item 15520.	
17370-A	Snowshoes , etc...☒Cancel; see item 15520.	
17460-A	Swings , NOI, chain or rope, see Note, item 17462, etc...☒Cancel; see item 15520.	
17462-A	NOTE—☒Cancel; no further application.	
17465-A	Swings , rope, with hollow plastic seat, with or without mounting hardware, etc...☒Cancel; see item 15520.	
17470-A	Swivels , exercise, steel or steel and wood combined, with or without rubber foot mat, etc...☒Cancel; see item 15520.	
17540-A	Targets , clay, pitch or limestone composition, etc...☒Cancel; see item 181920.	
17560-A	Targets or Target Butts or Mats , hay, grass, straw or wood excelsior, with or without paper or cloth covering or facing, printed or not printed, etc...☒Cancel; see item 181920.	
17561-A	NOTE—☒Cancel; no further application.	
17600-A	Tees or Pegs , golf, see Note, item 17601, etc...☒Cancel; see item 15520.	
17601-A	NOTE—☒Cancel; no further application.	
17660-A	Tows (Ropes) , water skiing, with or without handles, see Note, item 17662, etc...☒Cancel; see item 15520.	
17662-A	NOTE—☒Cancel; no further application.	
17685-A	Track or Field House: ...☒Cancel; no further application.	
17686-A	Balls , shot-putting, etc...☒Cancel; see item 15520.	
17687-A	Blocks , starting, etc...☒Cancel; see item 15520.	
17688-A	Boards , take-off or toe, wood, with or without cross-members, etc...☒Cancel; see item 15520.	
17689-A	Boxes , vaulting pole, steel or wood, etc...☒Cancel; see item 15520.	
17690-A	Circles , discus or shot-putting, steel, hinged, folded, etc...☒Cancel; see item 15520.	
17691-A	Cross Bars , wood or metal, for jump or vault standards, etc...☒Cancel; see item 15520.	
17692-A	Discus , aluminum, rubber or wood and steel combined, etc...☒Cancel; see item 15520.	
17693-A	Hammers , throwing, etc...☒Cancel; see item 15520.	
17694-A	Hurdles , track, metal or wood, with crossbars made of same or other materials, etc...☒Cancel; see item 15520.	
17695-A	Standards , jump, vault or finish line, iron or steel, etc...☒Cancel; see item 15520.	
17697-A	NOTE—☒Cancel; no further application.	
17698-A	Tubes , golf club shaft protector or separator, or golf ball pickup, plastic, other than cellular, expanded or foam plastic, etc...☒Cancel; see item 15520.	
17740-A	Weights , body balancing or training, lead and cloth, leather or plastic, etc...☒Cancel; see item 15520.	
	AUTOMOBILE PARTS GROUP: subject to item 17800	
▶18460-A	Covers , seat, radiator, spring, steering wheel, tire, top or hood, including Front-End Bras , in boxes.....	175
18462-A	Covers , seat, etc...☒Cancel; see item 18460.	
▶23700-A	Blackboards or Chalkboards; Corkboards or Tackboards; or Whiteboards, Dry Erase Boards or Markerboards , NOI; see Notes, items 23702 and 23703; in boxes or crates, see Note, item 23701, or in Package 2532:	
Sub 1	Greatest dimension exceeding 192 inches, subject to Item 170 and having a density in pounds per cubic foot of:	
Sub 2	Less than 6	400
Sub 3	6 but less than 10.....	200
Sub 4	10 or greater	100
Sub 5	Greatest dimension exceeding 96 inches but not exceeding 192 inches, subject to Item 170 and having a density in pounds per cubic foot of:	
Sub 6	Less than 6	300
Sub 7	6 but less than 10.....	175
Sub 8	10 or greater	92.5
Sub 9	Greatest dimension not exceeding 96 inches, subject to Item 170 and having a density in pounds per cubic foot of:	
Sub 10	Less than 6	250
Sub 11	6 but less than 10.....	150
Sub 12	10 or greater	85
△23701-A	NOTE—Corners, edges and sides of articles must be protected by interior packing forms necessary to afford adequate protection against damage from the normal rigors of the less-than-truckload environment.	
★23702	NOTE—Also applies on boards made of glass.	
★23703	NOTE—Does not apply on electronic whiteboards. For applicable provisions, see item 118258.	
33430-A	Buffing or Polishing Compounds , including Boat, Floor, Furniture or Vehicle Polish or Wax , impregnated into paper or cloth for buffing or polishing purposes, see Note, item 33431, etc...☒Cancel; see item 160460.	
33431-A	NOTE—☒Cancel; no further application.	

ITEM	ARTICLE	CLASS
33440-A	☒ Buffing or Polishing Compounds , NOI, including Boat, Floor, Furniture or Vehicle Polish or Wax , see Note, item 33442, etc...☒Cancel; see item 160460 and provisions otherwise applicable.	
33442-A	NOTE—☒Cancel; no further application.	
	BUILDING MATERIALS, MISCELLANEOUS, GROUP: subject to item 33570	
△34282-A	NOTE—Also applies on accompanying hardware, angles, bars, castings, chain, cable, guides, hoods, pipe, rollers, springs, motors, sprockets, track, hinges, sheaves, brackets, handles, locks, hangers, rails, hooks, pulleys, rods or other fittings when in same package with the doors, door sections, grilles, partitions or shutters, or, when in shipments of 36,000 pounds or more, separate packages.	
△35085-A	Partitions or Walls, interior, or Panels therefor , with or without integral doors, constructed with metal or wood frames and rigid facings, see Notes, items 34282, 35086 and 35087, in boxes or crates:	
Sub 1	Greatest dimension exceeding 96 inches, subject to Item 170 and having a density in pounds per cubic foot of:	
Sub 2	Less than 10	150
Sub 3	10 but less than 15	92.5
Sub 4	15 or greater	77.5
Sub 5	Greatest dimension not exceeding 96 inches, subject to Item 170 and having a density in pounds per cubic foot of:	
Sub 6	Less than 10	125
Sub 7	10 but less than 15	85
Sub 8	15 or greater	70
△35086-A	NOTE—Cores (all space within frames and between facings) must be of cellular or solid construction or consist of insulating materials. Rigid facings may be of any material or combination of materials.	
35087-A	NOTE—Does not apply on:	
	(1) Freestanding panels, partitions or screens. For applicable provisions, see item ►79300.	
	(2) Cooling or freezing room panels or walls. For applicable provisions, see items 53025 and 53180.	
►35255-A	Railings, NOI:	
Sub 1	In boxes or crates, subject to Item 170 and having a density in pounds per cubic foot of:	
Sub 2	Less than 5	250
Sub 3	5 but less than 10.....	125
Sub 4	10 but less than 15.....	85
Sub 5	15 but less than 22.5.....	70
Sub 6	22.5 or greater	60
Sub 7	In packages other than boxes or crates, see Note, item 35256, subject to Item 170 and having a density in pounds per cubic foot of:	
Sub 8	Less than 5	300
Sub 9	5 but less than 10.....	150
Sub 10	10 but less than 15.....	92.5
Sub 11	15 but less than 22.5.....	77.5
Sub 12	22.5 or greater	65
★35256	NOTE—Articles tendered for shipment on lift truck skids, pallets or platforms must be securely fastened to and must not overhang the edges of the lift truck skid, pallet or platform deck. Exposed surfaces and edges must be protected by packing forms or other packaging materials so as to withstand the normal rigors of the less-than-truckload environment.	
	BUILDING METALWORK GROUP: subject to item 35600	
△35932-A	NOTE—When in shipments of 24,000 pounds or more, provisions include accompanying equipment of hangers.	
36180-A	Conductor Pipe (Downspout), Conductor Pipe (Downspout) Cutoffs, Elbows, NOI, Funnels or Shoes; aluminum, etc...☒Cancel; see item 37020.	
36190-A	Conductor Pipe (Downspout), Conductor Pipe (Downspout) Cutoffs, Elbows, Funnels or Shoes; copper, lead or zinc, see Note, item 35932, etc...☒Cancel; see item 37020.	
△36192-A	NOTE—Item 110, Sec. 13 will govern, except the words 'two or more' may be substituted for 'three or more.'	
36210-A	Conductor Pipe (Downspout), Conductor Pipe (Downspout) Cutoffs, Elbows, Funnels or Shoes; iron, steel or tin plate, see Note, item 35932, etc...☒Cancel; see item 37020.	
36212-A	NOTE—☒Cancel; no further application.	
36220-A	Conductor Pipe Boots or Connections , cast iron...☒Cancel; see item 37020.	
36410-A	Eave Troughs; Roof Gutters; or Eave Trough or Roof Gutter End Caps, End Pieces, Mitres (Corners), Outlets, Slip Joint Connectors or Fittings , NOI; see Note, item 35932, etc...☒Cancel; see item 37020.	
36411-A	NOTE—☒Cancel; no further application.	
36450-A	Elbows , conductor pipe (downspout), cast aluminum, etc...☒Cancel; see item 37020.	

SUPPLEMENT 2 TO NMF 100-AW

ITEM	ARTICLE	CLASS
	BUILDING METALWORK GROUP: subject to item 35600	
★37020	Roof Gutters, Eavestroughs or Downspouts, or Fittings therefor, metal, in packages, see Note, item 37021:	
Sub 1	Greatest dimension exceeding 288 inches, subject to Item 170 and having a density in pounds per cubic foot of:	
Sub 2	Less than 5	500
Sub 3	5 but less than 10	250
Sub 4	10 or greater	110
Sub 5	Greatest dimension exceeding 192 inches but not exceeding 288 inches, subject to Item 170 and having a density in pounds per cubic foot of:	
Sub 6	Less than 5	400
Sub 7	5 but less than 10	200
Sub 8	10 or greater	100
Sub 9	Greatest dimension exceeding 96 inches but not exceeding 192 inches, subject to Item 170 and having a density in pounds per cubic foot of:	
Sub 10	Less than 5	300
Sub 11	5 but less than 10	175
Sub 12	10 or greater	92.5
Sub 13	Greatest dimension not exceeding 96 inches, subject to Item 170 and having a density in pounds per cubic foot of:	
Sub 14	Less than 5	250
Sub 15	5 but less than 10	150
Sub 16	10 or greater	85
★37021	NOTE—Articles tendered for shipment on lift truck skids, pallets or platforms must be securely fastened to and must not overhang the edges of the lift truck skid, pallet or platform deck. Exposed surfaces and edges must be protected by packing forms or other packaging materials so as to withstand the normal rigors of the less-than-truckload environment.	
40215-A	Cans, Containers, Dispensers or Tanks, fuel storage, rectangular construction, with or without folding steel spouts, sheet steel 20 gauge or thicker, etc...☒Cancel; see item 174610.	
40217-A	Cans, Containers, Dispensers or Tanks, sheet steel 24 gauge or thicker, other than rectangular, fuel storage, hand-portable safety type, with flash arrester and having a liquid capacity not exceeding 5 gallons, etc...☒Cancel; see item 174610.	
40220-A	CAPS AND COVERS GROUP, etc...☒Cancel; no further applicaiton.	
40222-A	NOTE—☒Cancel; no further application.	
★40225	Caps, Covers, Discs, Ends, Bands, Lids, Rings or Tops, NOI, for bottles, cans, cups, collapsible tubes, glasses, jars or jugs, see Note, item 40226, in boxes, subject to Item 170 and having a density in pounds per cubic foot of:	
Sub 1	Less than 1	400
Sub 2	1 but less than 2	300
Sub 3	2 but less than 4	250
Sub 4	4 but less than 6	175
Sub 5	6 but less than 8	125
Sub 6	8 but less than 10	100
Sub 7	10 but less than 12	92.5
Sub 8	12 but less than 15	85
Sub 9	15 but less than 22.5	70
Sub 10	22.5 but less than 30	65
Sub 11	30 or greater	60
★40226	NOTE—Also applies on Bands, Sleeves or Wrappers made of heat-shrinkable tubular plastic film, cut to size, such as used for product labeling, securement or to protect against tampering.	
40230-A	Aluminum, NOI, Brass, Bronze, Copper, Nickel, Silver or White Metal, etc...☒Cancel; see item 40225.	
40235-A	Bands, Sleeves or Wrappers, heat shrinkable tubular plastic film, see Note, item 40236, cut to size, printed or not printed, KD flat, etc...☒Cancel; see item 40225.	
40236-A	NOTE—☒Cancel; no further application.	
40240-A	Bottle Caps, steel or tin, separate or combined with aluminum, crimped edge, see Note, item 40242, lined with cork, paperboard or plastic, without attachments, etc...☒Cancel; see item 40225.	
40242-A	NOTE—☒Cancel; no further application.	
40245-A	Can Ends, see Note, item 40247, etc...☒Cancel; see item 40225.	
40247-A	NOTE—☒Cancel; no further application.	
40255-A	Caps, Covers, Discs, Ends or Tops, NOI, fiberboard, paper or pulpboard, with or without fasteners, for bottles, cans, cups, collapsible tubes, glasses, jars or jugs, etc...☒Cancel; see item 40225.	
40265-A	Caps, Covers, Discs, Ends, Bands, Rings or Tops, NOI, other than plastic, with or without fasteners, for bottles, cans, cups, collapsible tubes, glasses, jars or jugs, etc...☒Cancel; see item 40225.	
40290-A	Caps, Covers or Tops, dispensing, for pressurized cans or bottles; or Assembled Parts thereof, NOI, etc...☒Cancel; see item 40225.	
40300-A	Cellulose Bands, Caps, Covers or Tops, for bottles, cans, glasses or jars, cut-to-size or other than cut-to-size, see Note, item 40304, etc...☒Cancel; see item 40225.	
40304-A	NOTE—☒Cancel; no further application.	
40305-A	Discs or Lids, steel or tin plate, with sealing compound, see Note, item 40307, etc...☒Cancel; see item 40225.	
40307-A	NOTE—☒Cancel; no further application.	
40310-A	Fiberboard, Paper or Pulpboard, other than disks, NOI, etc...☒Cancel; see item 40225.	
40320-A	Fiberboard, plastic treated, screw type, etc...☒Cancel; see item 40225.	
40330-A	Foil or Foil and Paper combined, NOI, etc...☒Cancel; see item 40225.	
40350-A	Glass or Glass and Metal combined, with or without fasteners, etc...☒Cancel; see item 40225.	
40360-A	Milk Bottle Caps, aluminum foil or aluminum foil and paper combined, etc...☒Cancel; see item 40225.	
40370-A	Milk Bottle Caps, pulpboard, see Note, item 40372...☒Cancel; see item 40225.	
40372-A	NOTE—☒Cancel; no further application.	

ITEM	ARTICLE	CLASS
	CAPS AND COVERS GROUP: subject to item 40220	
40375-A	Mounting Covers , sheet steel, with or without rubber gaskets, without valves or tubes, for pressurized cans or bottle caps, covers or tops, etc...☒Cancel; see item 40225.	
40390-A	Paper or Pulpboard , snap-on type, etc...☒Cancel; see item 40225.	
	CARBON: subject to item 40550	
40570-A	Briquettes , NOI, etc...☒Cancel; see item 42445.	
▶42445-A	Charcoal, Charcoal Briquettes or Charcoal Pellets , NOI, not activated, not required by the U.S. Department of Transportation to bear a Hazard Class or Hazard Division label or placard, see Note, item 42446, in bags or boxes, subject to Item 170 and having a density in pounds per cubic foot of:	
Sub 1	Less than 10.....	110
Sub 2	10 but less than 15.....	85
Sub 3	15 but less than 30.....	70
Sub 4	30 or greater.....	60
△42446-A	NOTE—Does not apply on materials regulated by the U.S. Department of Transportation as hazardous and required to bear a Hazard Class or Hazard Division label or placard. For classes applicable to such hazardous materials, see provisions elsewhere in this Classification.	
42450-A	Charcoal or Charcoal Briquettes , coconut shell, nut shell, NOI, or fruit pit, not activated, not required by the U.S. Department of Transportation to bear a Hazard Class or Hazard Division label or placard, see Note, item 42451, etc...☒Cancel; see item 42445.	
42451-A	NOTE—☒Cancel; no further application.	
	CLOTH, FABRIC, DRY GOODS OR TEXTILES GROUP: subject to item 48920	
49280-A	Cloths , polishing, cotton, wax or chemically treated, etc...☒Cancel; see item 160460.	
52860-A	COOKWARE GROUP , etc...☒Cancel; no further application.	
52870-A	Broilers , iron or wire, NOI, flat or nested, etc...☒Cancel; see item 52880.	
▶52880-A	Cookware or Bakeware , metal, NOI, other than electric or gas, with or without components or accessories of same or other materials, see Notes, items 52881 and 52882, in boxes or crates, subject to Item 170 and having a density in pounds per cubic foot of:	
Sub 1	Less than 1.....	400
Sub 2	1 but less than 2.....	300
Sub 3	2 but less than 4.....	250
Sub 4	4 but less than 6.....	175
Sub 5	6 but less than 8.....	125
Sub 6	8 but less than 10.....	100
Sub 7	10 but less than 12.....	92.5
Sub 8	12 but less than 15.....	85
Sub 9	15 but less than 22.5.....	70
Sub 10	22.5 but less than 30.....	65
Sub 11	30 or greater.....	60
△52881-A	NOTE—Covers or other accessories may be in same or separate packages.	
★52882	NOTE—Also applies on Percolators or Teakettles , other than electric or gas.	
52904-A	Corn Poppers , household, other than electric, etc...☒Cancel; see item 52880.	
52910-A	Griddles , frying, other than electric, etc...☒Cancel; see item 52880.	
52920-A	Kettles , canning (Boilers or Retorts), iron...☒Cancel; see item 52880.	
52940-A	Percolators , coffee, household, sheet steel, enameled, other than self-heating, etc...☒Cancel; see item 52880.	
52950-A	Percolators , copper or sheet steel, NOI, other than electric, etc...☒Cancel; see item 52880.	
52960-A	Pressure Cookers , household, other than electric, etc...☒Cancel; see item 52880.	
52980-A	Sets , baking or cooking, consisting of glass baking dishes and plastic microwave cooking dishes or racks, with or without glass mixing bowl, etc...☒Cancel; see provisions otherwise applicable.	
52990-A	Teakettles , brass, bronze or copper, other than electric, etc...☒Cancel; see item 52880.	
	DECORATIONS GROUP: subject to item 55750	
56060-A	Fruit , artificial, other than plastic, etc...☒Cancel; obsolete.	
	DENTAL, HOSPITAL, MEDICAL OR SURGICAL SUPPLY GROUP: subject to item 56400	
△56840-A	Pumps or Aspirators , suction or pressure, including Breast Pumps , with or without appliances for drainage or other treatment of body cavities, see Note, item 56841, in boxes.....	125
56841-A	NOTE—Does not apply on devices that attach to central dental, hospital or medical vacuum supply systems. For applicable provisions, see item ▶56590.	
57170-A	Devices or Converters , catalytic, internal combustion engine exhaust system, etc...☒Cancel; see item 125850.	
58400-A	☒Dressing, belt, etc...☒Cancel; see item 160460 and provisions otherwise applicable.	
58420-A	☒Dressing or Blacking, NOI, automobile top, carrier's, harness, shoe, including Shoe Whitener (Cleaner) , stove (Stove Polish) or leather, other than belt, see Note, item 58422, etc...☒Cancel; see item 160460 and provisions otherwise applicable.	
58422-A	NOTE—☒Cancel; no further application.	
	DRUGS, MEDICINES, TOILET PREPARATIONS OR PERSONAL CARE PRODUCTS GROUP: subject to item 58500	
58560-A	☒Bay Rum, etc...☒Cancel; obsolete.	
△58692-A	NOTE—Will also apply on packages containing surgical instruments or veterinarian supplies not in excess of 5 percent of gross weight of package. Where weight of such articles exceeds 5 percent of gross weight of package, Item 640 will apply.	

ITEM	ARTICLE	CLASS
	DRUGS, MEDICINES, TOILET PREPARATIONS OR PERSONAL CARE PRODUCTS	
	GROUP: subject to item 58500	
▶58770-A	Drugs or Medicines , NOI, not required by the U.S. Department of Transportation to bear a Hazard Class or Hazard Division label or placard, see Notes, items 58771, 58772 and 58774, in boxes, drums, pails, intermediate bulk containers (IBCs) or Package 2407, subject to Item 170 and having a density in pounds per cubic foot of:	
Sub 1	Less than 1	400
Sub 2	1 but less than 2.....	300
Sub 3	2 but less than 4.....	250
Sub 4	4 but less than 6.....	175
Sub 5	6 but less than 8.....	125
Sub 6	8 but less than 10.....	100
Sub 7	10 but less than 12.....	92.5
Sub 8	12 but less than 15.....	85
Sub 9	15 but less than 22.5.....	70
Sub 10	22.5 but less than 30.....	65
Sub 11	30 or greater	60
△58771-A	NOTE—Does not apply on materials regulated by the U.S. Department of Transportation as hazardous and required to bear a Hazard Class or Hazard Division label or placard. For classes applicable to such hazardous materials, see provisions elsewhere in this Classification.	
58772-A	NOTE—▶Does not apply on cocaine, codeine, heroin, morphine or opium, which will not be accepted.	
58773-A	NOTE—☒Cancel; no further application.	
★58774	NOTE—Does not apply on dietary supplements or vitamins.	
58920-A	Lard , benzoinated, etc...☒Cancel; obsolete.	
59040-A	Nuts , areca (Betel Nuts), ground or powdered, etc...☒Cancel; obsolete.	
59050-A	Nuts , areca (Betel Nuts), not ground nor powdered, etc...☒Cancel; obsolete.	
59230-A	Sanitary Napkins or Pads , etc...☒Cancel; see item 59413.	
	Sea Grass, Sea Moss or Seaweed: subject to item 59240	
59270-A	Dulse , etc...☒Cancel; obsolete.	
★59413	Tampons, Pads or Sanitary Napkins , feminine hygiene, in boxes.....	150
59415-A	Tampons , etc...☒Cancel; see item 59413.	
	ELECTRICAL EQUIPMENT GROUP: subject to item 60500	
62515-A	Masks , aperture, color cathode ray tube, unfinished sheets, steel, etc...☒Cancel; obsolete.	
△63420-A	Transformers , NOI, or Transformer Parts , NOI, see Notes, items 63423 and 63424:	
Sub 1	In boxes or crates, or in doublewall fiberboard containers securely fastened to lift truck skids or pallets.....	70
Sub 2	In packages other than as set forth in sub 1.....	85
△63423-A	NOTE—Will not apply on paper or paperboard coil winding cores or tubes.	
63424-A	NOTE—Will not apply on plastic transformer cores. Refer to the provisions of item ▶156600.	
△63595-A	Enclosures or Structures; Promotional or Advertising Figures or Images; or Amusements , including Games, Bouncers, Rides or Slides ; inflatable or air-supported, deflated, see Note, item 63596, with or without accompanying blower and other equipment necessary for operation:	
Sub 1	In packages other than boxes or crates	150
Sub 2	In boxes or crates	125
	FARM EQUIPMENT GROUP: subject to item 64600	
65740-A	Racks , feed, wooden, etc...☒Cancel; obsolete.	
65930-A	Spraying Pens or Chutes , livestock, NOI, wood and steel combined, with or without spraying equipment...☒Cancel; obsolete.	
68200-A	FIBERS: ...☒Cancel; no further application.	
68210-A	Absorbent , cotton, NOI, etc...☒Cancel; see item 68310.	
68240-A	Carao (Cocoa) , etc...☒Cancel; see item 68310.	
68260-A	Casein , etc...☒Cancel; see item 68310.	
68280-A	Coconut Husk (Cocoa or Coir Fiber) , brush (Brush Making), etc...☒Cancel; see item 68310.	
68290-A	Coconut Husk (Cocoa or Coir Fiber) , curled (Coir Hair), etc...☒Cancel; see item 68310.	
68300-A	Coconut Husk (Cocoa or Coir Fiber) , NOI, etc...☒Cancel; see item 68310.	
▶68310-A	Fibers , NOI, see Note, item 68311, in bags, bales or boxes, subject to Item 170 and having a density in pounds per cubic foot of:	
Sub 1	Less than 1.....	400
Sub 2	1 but less than 2	300
Sub 3	2 but less than 4	250
Sub 4	4 but less than 6	175
Sub 5	6 but less than 8	125
Sub 6	8 but less than 10	100
Sub 7	10 but less than 12	92.5
Sub 8	12 but less than 15	85
Sub 9	15 but less than 22.5.....	70
Sub 10	22.5 but less than 30.....	65
Sub 11	30 or greater	60
△68311-A	NOTE—Also applies on Cotton, Wool or Synthetic Fiber Nubs.	
68320-A	Flax , etc...☒Cancel; see item 68310.	
68340-A	Grass Fiber , NOI, etc...☒Cancel; see item 68310.	
68360-A	Hemp , etc...☒Cancel; see item 68310.	
68380-A	Istle (Tampico) , etc...☒Cancel; see item 68310.	
68400-A	Jute, Jute Lashing, Jute Rejections or Benares Sunn , etc...☒Cancel; see item 68310.	
68420-A	Kapok , etc...☒Cancel; see item 68310.	

ITEM	ARTICLE	CLASS
68430-A 68440-A 68460-A 68500-A 68520-A 68540-A 68550-A 68560-A 68580-A 68600-A 68620-A	<p>FIBERS: subject to item 68200</p> <p>Manila or Sisal, etc...☒Cancel; see item 68310.</p> <p>Milkweed Floss, etc...☒Cancel; see item 68310.</p> <p>Palm or Palmetto, other than broom splints, etc...☒Cancel; see item 68310.</p> <p>Plastering, NOI, etc...☒Cancel; see item 68310.</p> <p>Plastering, wood, etc...☒Cancel; see item 68310.</p> <p>Ramie (China Grass Fiber), etc...☒Cancel; see item 68310.</p> <p>Steel, not over 1/4 inch in length, etc...☒Cancel; see item 68310.</p> <p>Tow, flax, etc...☒Cancel; see item 68310.</p> <p>Typha, not processed, etc...☒Cancel; see item 68310.</p> <p>Yucca, etc...☒Cancel; see item 68310.</p> <p>Zacaton (Mexican Rice Root), etc...☒Cancel; see item 68310.</p>	
△73150-B Sub 1 Sub 2 Sub 3 Sub 4	<p>FOODSTUFFS GROUP: subject to item 72000</p> <p>Flour, Meal or Sugar, viz.:</p> <p>Flour, NOI;</p> <p>Meal, NOI, including Corn Meal;</p> <p>Mixes, baking, NOI, including Bread, Brownie, Cake, Cookie, Muffin, Pancake or Waffle Mixes, see Note, item 73151;</p> <p>Mixes, batter, breading or coating, NOI;</p> <p>Sugar, NOI;</p> <p>In bags, boxes, drums or Packages 128 or 2456, subject to Item 170 and having a density in pounds per cubic foot of:</p> <p>Less than 10.....</p> <p>10 but less than 15.....</p> <p>15 but less than 30.....</p> <p>30 or greater.....</p>	125 85 70 55
△73151-B	<p>NOTE—Also applies on other ingredients or complement of accessories necessary for completion of the finished product when packaged in same box.</p>	
73260-B Sub 1 Sub 2 Sub 3 Sub 4 Sub 5 Sub 6 Sub 7 Sub 8 Sub 9 Sub 10 Sub 11	<p>Foodstuffs, other than frozen, Group IV, viz.:</p> <p>Bakery Goods, NOI, also in Package 2428;</p> <p>► Beverage Preparations, NOI, see Note, item 73263, also in Packages 2330 or 2438;</p> <p>Coffee, Tea or Herbal Tea, NOI, see Note, item 73261, also in Packages 2330 or 2380;</p> <p>Cookies or Crackers, NOI, also in Package 2428;</p> <p>Desserts, Dessert Toppings or Related Foods, NOI, see Note, item 73262;</p> <p>Foodstuffs, NOI;</p> <p>Hot Chocolate or Hot Cocoa Mixes;</p> <p>► Juice, fruit or vegetable, including Juice Concentrates, Juice Beverages, Juice Drinks or Juice Powders or Crystals, see Note, item 73263, also in Packages 2438 or 2467;</p> <p>Pasta or Noodles, with or without other ingredients;</p> <p>Rice, cleaned or prepared, NOI, with or without other ingredients;</p> <p>Snack Foods, NOI;</p> <p>Soups or Soup Mixes;</p> <p>In bags, boxes, drums or Packages 128, 223, 510, 1000, 1400, 1500, 2093, 2231, 2404, 2414, 2416, 2421, 2425, 2463, 2498, 2499, 2500 or 2507, subject to Item 170 and having a density in pounds per cubic foot of:</p> <p>Less than 1.....</p> <p>1 but less than 2.....</p> <p>2 but less than 4.....</p> <p>4 but less than 6.....</p> <p>6 but less than 8.....</p> <p>8 but less than 10.....</p> <p>10 but less than 12.....</p> <p>12 but less than 15.....</p> <p>15 but less than 22.5.....</p> <p>22.5 but less than 30.....</p> <p>30 or greater.....</p>	400 300 250 175 125 100 92.5 85 70 65 60
△73261-B	<p>NOTE—Also applies on: instant, soluble, freeze-dehydrated or freeze-dried coffee, tea or herbal tea; coffee, tea or herbal tea in premeasured servings, with or without integral filter; or Coffee Service Kits or Sets, consisting of coffee in premeasured servings, with or without integral filter, and with or without non-dairy creamer, sugar or artificial sweetener, stirrers, tea, herbal tea or hot chocolate in same box.</p>	
△73262-B	<p>NOTE—Provisions for desserts, dessert toppings or related foods include, but are not limited to:</p> <p>Crusts, pie or tart;</p> <p>Dessert Mixes or Preparations, NOI;</p> <p>Dishes, Bowls, Ice Cream Cones or Shells, edible, NOI;</p> <p>Dough, prepared;</p> <p>Gelatine Dessert;</p> <p>Sauces or Toppings, ice cream or dessert, NOI, in other than pressurized containers, including Marshmallow Creme, Nuts (Nutmeats) in Syrup, or Sprinkles.</p>	
★73263 73360-A 73362-A 73570-A	<p>NOTE—Also applies on freeze-dehydrated or freeze-dried beverage preparations or juice powders or crystals.</p> <p>Fruit Juice Powders or Crystals, see Note, item 73362, etc...☒Cancel; see item 73260.</p> <p>NOTE—☒Cancel; see item 73263.</p> <p>Juice, fruit or vegetable, including Juice Concentrates, Juice Beverages or Juice Drinks; or Cider, fruit, including Cider Concentrates, nonalcoholic, etc...☒Cancel; see item 73260.</p>	

ITEM	ARTICLE	CLASS
	FOODSTUFFS GROUP: subject to item 72000	
74490-A	Preparations , beverage, NOI, dry or liquid, other than straws containing beverage preparations, see Note, item 74491, etc...☒Cancel; see item 73260.	
74491-A	NOTE—☒Cancel; see item 73263.	
	FURNITURE GROUP: subject to item 79000	
79110-A	Blackboards (Chalkboards) , portable, revolving or reversible, on stands, etc...☒Cancel; see item 23700.	
79132-A	Blackboards (Chalkboards) or Pegboards combined with Stands and Seats , plastic, steel and masonite combined, see Note, item 79134, KD flat, etc...☒Cancel; see item 23700.	
79134-A	NOTE—☒Cancel; no further application.	
79135-A	Blackboards (Chalkboards) or Pegboards combined with Stands and Seats , wooden or wood and steel combined, KD flat, etc...☒Cancel; see item 23700.	
	GAMES OR TOYS GROUP: subject to item 83900	
83985-A	Boards or Sticks , toy building or construction, cut to length, notched, wooden, in the white, etc...☒Cancel; see item 84260.	
83990-A	Blocks , school, educational construction, wooden, in the white, etc...☒Cancel; see item 84260.	
84000-A	Cap Pistol and Toy Pistol Caps , mounted on paper cards, etc...☒Cancel; see item 84260.	
84020-A	Cards , playing, etc...☒Cancel; see item 84260.	
84040-A	Checkers, Checkerboards or Checker Games , etc...☒Cancel; see item 84260.	
84080-A	Dish Sets , glass or pottery, etc...☒Cancel; see item 84260.	
84100-A	Doll Heads , in boxes or drums, or Doll Bodies , etc...☒Cancel; see item 84260.	
84140-A	Dominoes , etc...☒Cancel; see item 84260.	
84170-A	Games , card, children's, see Note, item 84172, etc...☒Cancel; see item 84260.	
84172-A	NOTE—☒Cancel; no further application.	
84175-A	Games , lottery type, paper or paperboard, see Note, item 84176, etc...☒Cancel; see item 84260.	
84176-A	NOTE—☒Cancel; see item 84264.	
▶84260-B	Games or Toys, viz.: Board Games, Card Games or Tile Games; Doll Carriages or Strollers; Dolls or Doll Clothing or Accessories; Equipment , toy or model railroad, see Note, item 84262; Games , lottery, see Note, item 84264; Games or Toys , NOI, see Note, item 84263; Kites; Model Kits , hobby or toy; Playing Cards; Puzzles; Stuffed Animals; Toy Guns , including Dart, Cap or Water Guns , see Note, item 84265; Video Game Consoles , other than coin- or currency-operated; Video Games , NOI, other than coin- or currency-operated, see Note, item 84261; In boxes or Packages 2213, 2249 or 2296, subject to Item 170 and having a density in pounds per cubic foot of: Less than 1..... 1 but less than 2..... 2 but less than 4..... 4 but less than 6..... 6 but less than 8..... 8 but less than 10..... 10 but less than 12..... 12 but less than 15..... 15 but less than 22.5..... 22.5 but less than 30..... 30 or greater.....	400 300 250 175 125 100 92.5 85 70 65 60
△84261-B	NOTE—Does not apply on cartridge-type video games as named in item 63025.	
△84262-B	NOTE—Applies on locomotives, cars, tracks or accessories whether or not in sets.	
★84263	NOTE—Does not apply on inflatable or air-supported enclosures, structures or promotional or advertising figures or images, nor on amusements, such as games, bouncers, rides or slides for use at outdoor picnics, birthday parties, fundraising or promotional events or other such festivities. For applicable provisions, see item 63595.	
★84264	NOTE—Applies on punch-out, pull-tab, scratch-off or peel-back type games employed in conducting games of chance.	
★84265	NOTE—Also applies on parts or accessories such as holsters, cap gun caps or toy projectiles.	
84270-A	Games or Toys , NOI, paper; in sheets, see Note, item 84271, etc...☒Cancel; see item 84260.	
84271-A	NOTE—☒Cancel; no further application.	
84300-A	Games or Toys , NOI, plastic or rubber, pneumatic, other than toy balloons, and other than balls, see Notes, items 84303 and 84304, etc...☒Cancel; see item 84260.	
84302-A	NOTE—☒Cancel; no further application.	
84303-A	NOTE—☒Cancel; see item 84263.	
84304-A	NOTE—☒Cancel; no further application.	
84340-A	Guns or Rifles , air, firing hollow projectiles, etc...☒Cancel; see item 84260.	
84360-A	Guns or Rifles , NOI, iron or steel, tin plate or wooden or wood combined with metal or plastic, or metal combined with plastic, see Notes, items 84362 and 84364, etc...☒Cancel; see item 84260.	
84362-B	NOTE—☒Cancel; see item 84265.	
84364-B	NOTE—☒Cancel; no further application.	
84410-A	Jackstones , etc...☒Cancel; see item 84260.	
84451-A	Kites , other than cellular, expanded or foam plastic, etc...☒Cancel; see item 84260.	

ITEM	ARTICLE	CLASS
	GAMES OR TOYS GROUP: subject to item 83900	
84452-A	NOTE—☒Cancel; no further application.	
84470-A	Merry-go-rounds , miniature, KD, etc...☒Cancel; see item 84260.	
84510-A	Modeling Compound , etc...☒Cancel; see item 84260.	
84570-A	Play Balls , NOI, spherical, solid or sponge rubber, not exceeding 3½ inches in diameter, etc...☒Cancel; see item 84260.	
84600-A	Playhouses , KD flat, etc...☒Cancel; see item 84260.	
84690-A	Sets , children's paper or paperback book and recorded cassette tape, etc...☒Cancel; obsolete.	
84700-A	Sets , construction, metal, completely disassembled, with or without motors, etc...☒Cancel; see item 84260.	
84702-A	Sets , modeling, see Note, item 84703, etc...☒Cancel; see item 84260.	
84703-A	NOTE—☒Cancel; no further application.	
84705-A	Sets , road race, see Note, item 84706...☒Cancel; see item 84260.	
84706-A	NOTE—☒Cancel; no further application.	
84710-A	Sets , record and book, children's, see Note, item 84711, etc...☒Cancel; obsolete.	
84711-A	NOTE—☒Cancel; no further application.	
84720-A	Springs , coiled flat wire with cloth, plastic, rubber or wooden parts, see Note, item 84722, etc...☒Cancel; see item 84260.	
84722-A	NOTE—☒Cancel; no further application.	
84730-A	Springs , walking, coiled flat wire, see Note, item 84732, etc...☒Cancel; see item 84260.	
84732-A	NOTE—☒Cancel; no further application.	
84750-A	Tops , other than plunger type; or Yo-Yo's , not exceeding 3½ inches in diameter; etc...☒Cancel; see item 84260.	
84770-A	Toy Blocks , nested, etc...☒Cancel; see item 84260.	
84790-A	Toy Blocks , solid; Kindergarten Blocks , solid; or Solid Toy Block Building Sets with equipment of bolts and nuts, other than foam or sponge rubber or cellular or expanded plastic, etc...☒Cancel; see item 84260.	
84792-A	NOTE—☒Cancel; no further application.	
84810-A	Toy Cannons or Guns , NOI, iron or steel, sheet 20 gauge or thicker or sheet and cast combined, with or without wooden stocks, or cast with wooden stocks or composition parts, etc...☒Cancel; see item 84260.	
84960-A	Toy Blocks , corrugated fiberboard, KD flat, etc...☒Cancel; see item 84260.	
84980-A	Wooden Paddles with rubber balls or vacuum caps attached, etc...☒Cancel; see item 84260.	
89000-A	GRAIN GROUP , etc...☒Cancel; no further application.	
89012-A	NOTE—☒Cancel; see item 89231.	
89030-A	Barley , etc...☒Cancel; see item 89230.	
89050-A	Buckwheat , etc...☒Cancel; see item 89230.	
89070-A	Corn , NOI, shelled or not shelled, etc...☒Cancel; see item 89230.	
89100-A	Grain Sorghums , such as durra, feterita, kafir, kaoliang, milo or shallu, etc...☒Cancel; see item 89230.	
89130-A	Oats , etc...☒Cancel; see item 89230.	
89150-A	Popcorn , not popped, NOI, in the ear, etc...☒Cancel; see item 89230.	
89170-A	Rye , etc...☒Cancel; see item 89230.	
89190-A	Spelt , etc...☒Cancel; see item 89230.	
89210-A	Wheat , etc...☒Cancel; see item 89230.	
★89230	Grain , see Note, item 89231, viz.: Barley; Corn; Grain , NOI; Oats; Rye; Wheat; In bags, boxes or drums.....	65
★89231	NOTE—Does not apply on grain represented as 'seed.' For applicable provisions, see item 173720.	
	GRAIN PRODUCTS GROUP: subject to item 89300	
89610-A	Malt Flour , etc...☒Cancel; see item 73150.	
89670-A	Meal , gluten, etc...☒Cancel; see item 73150.	
89770-A	Wheat Germ Meal , etc...☒Cancel; see item 73150.	
	GRAPHITE ARTICLES GROUP: subject to item 89850	
►89935-A	Graphite Articles , NOI, in boxes or crates, subject to Item 170 and having a density in pounds per cubic foot of:	
Sub 1	Less than 1	400
Sub 2	1 but less than 2	300
Sub 3	2 but less than 4	250
Sub 4	4 but less than 6	175
Sub 5	6 but less than 8	125
Sub 6	8 but less than 10	100
Sub 7	10 but less than 12.....	92.5
Sub 8	12 but less than 15.....	85
Sub 9	15 but less than 22.5.....	70
Sub 10	22.5 but less than 30.....	65
Sub 11	30 or greater	60
89937-A	NOTE—☒Cancel; no further application.	
91100-A	GUMS: ...☒Cancel; no further application.	
91180-A	Arabic , etc...☒Cancel; see item 91650.	
91260-A	Chewing Gum Base , see Note, item 91262, or Chicle , etc...☒Cancel; see item 91650.	
91262-A	NOTE—☒Cancel; no further application.	
91300-A	Copal , NOI, etc...☒Cancel; see item 91650.	
91320-A	Damar (Demar) , etc...☒Cancel; see item 91650.	

SUPPLEMENT 2 TO NMF 100-AW

ITEM	ARTICLE	CLASS
	GUMS: subject to item 91100	
91360-A	☉Ester, etc... ☒Cancel; see item 91650 and provisions otherwise applicable.	
91380-A	Gums, natural, NOI, etc... ☒Cancel; see item 91650.	
91420-A	Karaya, etc... ☒Cancel; obsolete.	
91460-A	Manila, etc... ☒Cancel; obsolete.	
91500-A	Pontianac, etc... ☒Cancel; see item 91650.	
91540-A	Shellac, etc... ☒Cancel; see item 91650.	
91560-A	Spruce, etc... ☒Cancel; see item 91650.	
91600-A	Turpentine, etc... ☒Cancel; see item 91650.	
★91650	Gums, natural, NOI, including Chicle, not required by the U.S. Department of Transportation to bear a Hazard Class or Hazard Division label or placard, see Note, item 91651, in bags, boxes, drums or intermediate bulk containers (IBCs), subject to Item 170 and having a density in pounds per cubic foot of:	
Sub 1	Less than 15	92.5
Sub 2	15 or greater	65
★91651	NOTE—Does not apply on materials regulated by the U.S. Department of Transportation as hazardous and required to bear a Hazard Class or Hazard Division label or placard. For classes applicable to such hazardous materials, see provisions elsewhere in this Classification.	
109990-A	Lawn Watering Systems, consisting of plastic or rubber hose or tubing, with metal or plastic fittings or sprinkler heads, etc... ☒Cancel; see item 178090.	
109992-A	NOTE—☒Cancel; no further application.	
	LUMBER GROUP: subject to item 112000	
112480-A	Eave Troughs or Gutters, roof, wooden, in the rough... ☒Cancel; obsolete.	
	MACHINERY GROUP: subject to item 114000	
125850-A	Mufflers, Exhaust Systems, Automobile Pipe, Surge Suppressors and related articles, viz.: Automobile Pipe or Tubing, steel, copper plate or terne plate, straight or bent, further processed than cut to length, see Note, item 125853; ►Catalytic Converters, internal combustion engine exhaust system; Exhaust Systems, internal combustion engine, see Note, item 125851; Hydraulic Accumulators; Industrial Noise, Pulsation or Surge Suppressors or Silencers, see Note, item 125852; Mufflers, Resonators, Spark Arresters or Silencers, internal combustion engine; In packages, subject to Item 170 and having a density in pounds per cubic foot of:	
Sub 1	Less than 1	400
Sub 2	1 but less than 2	300
Sub 3	2 but less than 4	250
Sub 4	4 but less than 6	175
Sub 5	6 but less than 8	125
Sub 6	8 but less than 10	100
Sub 7	10 but less than 12	92.5
Sub 8	12 but less than 15	85
Sub 9	15 but less than 22.5	70
Sub 10	22.5 but less than 30	65
Sub 11	30 or greater	60
125851-A	NOTE—Exhaust systems consist of mufflers, resonators or silencers and exhaust or tail pipes, with or without head pipes, collectors, manifolds, ►catalytic converters or mounting hardware.	
△125852-A	NOTE—Also applies on named commodities when combined with spark arresters or when having spark arresting capabilities.	
△125853-A	NOTE—Applies on the following types of automobile pipe or tubing: crankcase breather, crankcase ventilator, gasoline tank filler, exhaust, oil filler, oil strainer suction, radiator outlet, tailpipe or tailpipe extensions, or gas tank filler pipe fittings.	
△131670-A	Tools, power, other than power hand tools, with or without pedestals or stands, see Note, item 131672, viz.: Abrasive (Sanding) Machines; Cut-off Machines, abrasive disc type; Drill Presses, NOI; Grinders, see Note, item 131673, or Grinding or Polishing Heads; Jointers; Lathes, NOI, see Note, item 131674; Milling-Drilling Machines (Drill-Mills or Dovetail Mills); Mortisers; Planers; Saws, band, circular, radial, jig or scroll; Shapers;	
Sub 1	In boxes, crates or Package 2113, subject to Item 170 and having a density in pounds per cubic foot of:	
Sub 2	Less than 8	150
Sub 3	8 but less than 12	100
Sub 4	12 or greater	70
Sub 5	In packages other than boxes, crates or Package 2113, subject to Item 170 and having a density in pounds per cubic foot of:	
Sub 6	Less than 8	175
Sub 7	8 but less than 12	110
Sub 8	12 or greater	77.5

ITEM	ARTICLE	CLASS
△131672-A	NOTE—Applies on these articles when equipped or mounted on pedestals or stands that are a basic essential structural part of the power tool machine, and does not include pedestals or stands that are in the nature of accessorial equipment. Shipments may contain accessorial attachments for the tools named.	
△131673-A	NOTE—Also applies on tools identified as Milling Machines which use grinding as their means of milling.	
131674-A	NOTE—Does not apply on dental lathes, engravers' lathes, jewelers' lathes or watchmakers' lathes, nor on metalworking lathes weighing each 2,000 pounds or more. See item 123980 for applicable provisions for metalworking lathes weighing each 2,000 pounds or more, item ▶56590 for dental lathes and item 133300 for engravers' lathes, jewelers' lathes or watchmakers' lathes.	
142000-A	OFFICE OR STORE EQUIPMENT GROUP: ...☒Cancel; no further application.	
142050-A	Binders or Clamps , vertical filing, see Note, item 142052, etc...☒Cancel; see item 179180.	
142052-A	NOTE—☒Cancel; no further application.	
142060-A	Boards , clip or arch, wood, fiberboard, chemically hardened fiber or fiberboard wallboard, with or without fixtures, etc...☒Cancel; see item 179180.	
142085-A	Boxes, Files or Pockets , letter, document or invoice, paper, pulpboard or paper or pulpboard and wood combined, other than filing cases or cabinets, etc...☒Cancel; see item 179180.	
142230-A	Folders , file, plastic, etc...☒Cancel; see item 179180.	
142400-A	Moisteners , envelope or postage stamp, etc...☒Cancel; see item 179180.	
142440-A	Stencils , NOI, etc...☒Cancel; see item 179180.	
142460-A	Trays, Tray-binders, or Binder-trays , bookkeeping, adjustable, etc...☒Cancel; see item 179180.	
	PADS, PADDING AND RELATED ARTICLES GROUP: subject to item 149000	
△149265-B	Pads, Padding, Cushions or Pillows, viz.:	
	Batts or Batting , NOI;	
	Berms , spill containment;	
	Booms, Pads, Sweeps or Other Forms or Shapes , chemical or oil absorption;	
	Cushions , aircraft seat or railway car seat;	
	Cushions , automotive safety restraint system, cloth (Air Bag Inflator Cushions);	
	Cushions , NOI;	
	Excelsior , NOI; or Shredded Paper Packing Material ;	
	Futons ;	
	Mats or Matting , NOI;	
	Packing Material , loosefill, NOI, including Packing Peanuts, Pellets, Disks or Other Forms or Shapes ;	
	Pads , mattress;	
	Pads or Cushions , packing, NOI, including Bubble Wrap , see Note, item 149266;	
	Pads or Padding , NOI;	
	Pads , stove or table, NOI;	
	Pillows or Pillow Forms (Unfinished Pillows) , NOI;	
	Seat Backs , railway car, upholstered or padded;	
	Wads or Wadding , NOI;	
	In packages, subject to Item 170 and having a density in pounds per cubic foot of:	
Sub 1	Less than 1.....	400
Sub 2	1 but less than 2.....	300
Sub 3	2 but less than 4.....	250
Sub 4	4 but less than 6.....	175
Sub 5	6 but less than 8.....	125
Sub 6	8 but less than 10.....	100
Sub 7	10 but less than 12.....	92.5
Sub 8	12 but less than 15.....	85
Sub 9	15 but less than 22.5.....	70
Sub 10	22.5 but less than 30.....	65
Sub 11	30 or greater.....	60
△149266-A	NOTE—Also applies on Bags, Packets, Pouches or Sleeves for use as inner packaging material.	
150300-A	PALLETS GROUP , etc...☒Cancel; no further application.	
150310-A	Carriers or Pallets , flexible intermediate bulk container, constructed of corrugated fiberboard, paperboard or pulpboard sheets with halved fiberboard, paperboard or pulpboard tubes, assembled or unassembled, etc...☒Cancel; see item 150400.	
150345-A	Pallets , shipping, molded wood fiber or wood particles, with plastic resin binder, etc...☒Cancel; see item 150400.	
150370-A	Pallets, Platforms or Skids , for lift trucks, aluminum, with or without wooden or steel reinforcement, etc...☒Cancel; see item 150400.	
150380-A	Pallets, Platforms or Skids , for lift trucks, corrugated fiberboard combined with corrugated fiberboard-faced wood, veneer or plywood, etc...☒Cancel; see item 150400.	
150390-A	Pallets; Platforms; Racks , shipping, NOI; or Skids ; for lift trucks, plastic, steel or wood, with or without bodies, enclosures, ends, sides, stakes, standards or stacking posts, see Notes, items 150391 and 150392, etc...☒Cancel; see item 150400.	
150391-A	NOTE—☒Cancel; no further application.	
150392-A	NOTE—☒Cancel; no further application.	

SUPPLEMENT 2 TO NMF 100-AW

ITEM	ARTICLE	CLASS
<p>★150400</p> <p>Sub 1</p> <p>Sub 2</p> <p>Sub 3</p> <p>Sub 4</p> <p>Sub 5</p> <p>Sub 6</p> <p>Sub 7</p> <p>Sub 8</p> <p>Sub 9</p> <p>Sub 10</p> <p>Sub 11</p>	<p>Pallets, Platforms, Skids or Shipping Racks, NOI, for lift trucks, with or without bodies, enclosures, ends, sides, stakes, standards or stacking posts, subject to Item 170 and having a density in pounds per cubic foot of:</p> <p>Less than 1</p> <p>1 but less than 2</p> <p>2 but less than 4</p> <p>4 but less than 6</p> <p>6 but less than 8</p> <p>8 but less than 10</p> <p>10 but less than 12</p> <p>12 but less than 15</p> <p>15 but less than 22.5</p> <p>22.5 but less than 30</p> <p>30 or greater</p>	<p>400</p> <p>300</p> <p>250</p> <p>175</p> <p>125</p> <p>100</p> <p>92.5</p> <p>85</p> <p>70</p> <p>65</p> <p>60</p>
	<p>PALLETS GROUP: subject to item 150300</p>	
150430-A	<p>Pallets, Platforms or Skids, for lift trucks, fiberboard, paperboard or pulpboard, etc...☒Cancel; see item 150400.</p>	
150433-A	<p>Pallets or Platforms, for lift trucks, corrugated fiberboard, paperboard or pulpboard with molded plastic legs, etc...☒Cancel; see item 150400.</p>	
150435-A	<p>Pallets or Platforms, for lift trucks, fiberboard and cellular, expanded or foam plastic combined, etc...☒Cancel; see item 150400.</p>	
<p>★150550</p> <p>Sub 1</p> <p>Sub 2</p> <p>Sub 3</p> <p>Sub 4</p> <p>Sub 5</p>	<p>Paper, Paperboard, Fiberboard or Pulpboard, combined or not combined with other materials, NOI, in packages, see Note, item 150551, subject to Item 170 and having a density in pounds per cubic foot of:</p> <p>Less than 8</p> <p>8 but less than 12</p> <p>12 but less than 20</p> <p>20 but less than 30</p> <p>30 or greater</p>	<p>175</p> <p>100</p> <p>70</p> <p>65</p> <p>55</p>
★150551	<p>NOTE—Paper, paperboard, fiberboard or pulpboard tendered for shipment on lift truck skids, pallets or platforms must not overhang the skid, pallet or platform deck, and all exposed surfaces and edges must be protected by packing forms or other packaging materials so as to withstand the normal rigors of the less-than-truckload environment. Paper, paperboard, fiberboard or pulpboard in rolls must be secured to the lift truck skid, pallet or platform by strapping or other packaging methods to prevent shifting of the load. Paper, paperboard, fiberboard or pulpboard sheets stacked on lift truck skids, pallets or platforms must be secured to the lift truck skid, pallet or platform by strapping in opposing directions, with at least two straps in each direction. All corners and strapping contact points must be protected by packing forms.</p>	
150600-A	<p>PAPER, etc...☒Cancel; no further application.</p>	
150620-A	<p>Absorbent Base for Impregnation and Making Laminated Plastics, etc...☒Cancel; see item 150550.</p>	
150650-A	<p>Autographic Register, Calculator, Cash Register, Copying Machine, Data Processing Machine (Computer or Computer Printer) or Ticket Issuing Machine, other than forms, cards, checks or tickets, see Note, item 150652, plain, or ruled, not otherwise printed, see Note, item 150654, etc...☒Cancel; see item 150550.</p>	
150652-A	<p>NOTE—☒Cancel; no further application.</p>	
150654-A	<p>NOTE—☒Cancel; no further application.</p>	
150670-A	<p>Blotting; Cover, see Note, item 150674; Document Manila, see Note, item 150674; Drawing, see Note, item 150674; Matrix; Printing, NOI, other than newsprint or carbonized print, see Note, item 150674; Stereotype; or Writing, other than folded, not printed, see Notes, items 150672 and 150674; etc...☒Cancel; see item 150550.</p>	
150672-A	<p>NOTE—☒Cancel; no further application.</p>	
150674-A	<p>NOTE—☒Cancel; no further application.</p>	
150690-A	<p>Blueprint or Reproduction, NOI, sensitized, etc...☒Cancel; see item 150550.</p>	
150700-A	<p>Braided or Twisted; or Folded and Pressed into Strips, other than bag fasteners and other than fastening tape, tapes or ties; with or without wire center, etc...☒Cancel; see item 150550.</p>	
150720-A	<p>Calendar Roll, etc...☒Cancel; see item 150550.</p>	
150740-A	<p>Carbon, NOI, etc...☒Cancel; see item 150550.</p>	
150760-A	<p>Carbonizing, other than carbonized, etc...☒Cancel; see item 150550.</p>	
150780-A	<p>Carbonized Newsprint; or One-time Carbon Paper, see Note, item 150784, etc...☒Cancel; see item 150550.</p>	
150784-A	<p>NOTE—☒Cancel; no further application.</p>	
150805-A	<p>Cigarette Tipping, etc...☒Cancel; see item 150550.</p>	
150810-A	<p>Cigarette, uncut, etc...☒Cancel; see item 150550.</p>	
150850-A	<p>Cloth Lined, NOI, gummed or not gummed, etc...☒Cancel; see item 150550.</p>	
150890-A	<p>Cover or Lining, box, suitcase or trunk, printed, etc...☒Cancel; see item 150550.</p>	
150910-A	<p>Crepe, tissue, other than streamers, NOI, etc...☒Cancel; see item 150550.</p>	
150930-A	<p>Enameled, Glazed or Surface Coated, NOI, printed or not printed, see Notes, items 150932 and 150934, etc...☒Cancel; see item 150550.</p>	
150932-A	<p>NOTE—☒Cancel; no further application.</p>	
150934-A	<p>NOTE—☒Cancel; no further application.</p>	
150936-A	<p>NOTE—☒Cancel; see item 150551.</p>	
150950-A	<p>Fiber-stock, NOI (paper for making chemically hardened fiber), etc...☒Cancel; see item 150550.</p>	
150970-A	<p>Filter Stock, see Note, item 150971, etc...☒Cancel; see item 150550.</p>	
150971-A	<p>NOTE—☒Cancel; no further application.</p>	
150990-A	<p>Government Pulp (Macerated Paper Currency Pulp), etc...☒Cancel; see item 150550.</p>	
151010-A	<p>Ground Wood Paper, other than newsprint and unfinished blank wallpaper, fiber content consisting of not less than 60 percent ground wood, including such papers as catalog, directory, drawing, manila, novel, poster, printing, tablet or writing paper, see Notes, items 151012 and 151132, etc...☒Cancel; see item 150550.</p>	
151012-A	<p>NOTE—☒Cancel; no further application.</p>	

SUPPLEMENT 2 TO NMF 100-AW

ITEM	ARTICLE	CLASS
151030-A	PAPER: subject to item 150600 Gummed , other than cloth-lined, NOI, protected with waterproofed paper wrapping, printed or not printed, etc...☒Cancel; see item 150550.	
151050-A	Imitation Colored or Stained Glass , etc...☒Cancel; see item 150550.	
151070-A	Lace , etc...☒Cancel; see item 150550.	
151110-A	Lining , envelope, printed, etc...☒Cancel; see item 150550.	
151130-A	Newsprint Paper , bagasse (crushed sugar cane refuse) or bagasse (crushed sugar cane refuse) and other fibers combined, see Note, item 151132, etc...☒Cancel; see item 150550.	
151132-A	NOTE—☒Cancel; no further application.	
151150-A	Newsprint Paper , fiber content consisting of not less than 60 percent ground wood, see Notes, items 151132 and 151152, etc...☒Cancel; see item 150550.	
151152-A	NOTE—☒Cancel; no further application.	
151170-A	Oil Board , etc...☒Cancel; see item 150550.	
151190-A	Packing , see Note, item 151192, etc...☒Cancel; see item 150550.	
151192-A	NOTE—☒Cancel; no further application.	
151210-A	Paper , dusting or polishing, etc...☒Cancel; see item 150550.	
151230-A	Paper or Paperboard , flock coated or printed with flock, etc...☒Cancel; see item 150550.	
151240-A	Paper , latex impregnated, etc...☒Cancel; see item 150550.	
151250-A	Paper , NOI, not printed, etc...☒Cancel; see item 150550.	
151270-A	Pari-mutuel Ticket Issuing Machine Paper , printed, requiring further printing, etc...☒Cancel; see item 150550.	
151280-A	Phenolic Resin Impregnated , not coated, not laminated nor hardened nor set by heat, etc...☒Cancel; see item 150550.	
151290-A	Photographic , sensitized, etc...☒Cancel; see item 150550.	
151300-A	Printing , other than newsprint or carbonized print, see Note, item 150674; rejected, having value only for reclamation of materials, see Note, item 151301, etc...☒Cancel; see item 150550.	
151301-A	NOTE—☒Cancel; no further application.	
151315-A	Pulpboard, Fiberboard, Paper or Paperboard , NOI, corrugated, fluted or indented, see Notes, items 151317 and 151318, etc...☒Cancel; see item 150550.	
151317-A	NOTE—☒Cancel; no further application.	
151318-A	NOTE—☒Cancel; no further application.	
151320-A	Pulpboard, Fiberboard or Paperboard , NOI, not corrugated, fluted nor indented, see Notes, items 151317 and 151318, etc...☒Cancel; see item 150550.	
151370-A	Resin Impregnated , not laminated, NOI, etc...☒Cancel; see item 150550.	
151390-A	Scrap or Waste , etc...☒Cancel; see item 150550 and provisions otherwise applicable.	
151392-A	NOTE—☒Cancel; no further application.	
151393-A	NOTE—☒Cancel; no further application.	
151395-A	Shelf Covering or Drawer Lining , paper, foil and plastic combined, etc...☒Cancel; see item 150550.	
151400-A	Store or Window Decorative or Display , not printed, or printed with advertising or other than advertising matter, etc...☒Cancel; see item 150550.	
151402-A	NOTE—☒Cancel; no further application.	
151440-A	Tissue , NOI, printed or not printed, other than tissue wrapping paper, etc...☒Cancel; see item 150550.	
151460-A	Toilet Paper, Napkin Paper or Paper Toweling , see Note, item 151461, etc...☒Cancel; see item 150550.	
151461-A	NOTE—☒Cancel; no further application.	
151500-A	Vegetable Parchment Lining or Wrapping Paper , crinkled or not crinkled, printed or not printed, etc...☒Cancel; see item 150550.	
151520-A	Vegetable Parchment , NOI, printed or not printed, etc...☒Cancel; see item 150550.	
151620-A	☉ Waste , ground, etc...☒Cancel; see item 150550.	
151630-A	Wax Paper (Waxed Paper) , etc...☒Cancel; see item 150550.	
151640-A	Window Shade , etc...☒Cancel; see item 150550.	
151660-A	Wrappers , NOI, other than government stamped, printed, edges gummed or not gummed; or made of one piece of paper, not printed, edges gummed, see Notes, items 151662 and 151664, etc...☒Cancel; see item 150550.	
151662-A	NOTE—☒Cancel; no further application.	
151664-A	NOTE—☒Cancel; no further application.	
151680-A	Wrappers , vegetable parchment, other than government stamped, printed, edges gummed or not gummed; or made of one piece of paper, not printed, edges gummed, see Note, item 151662, etc...☒Cancel; see item 150550.	
151780-A	Wrapping , decorative, including Gift Wrapping Paper or Paper-Backed Foil , in rolls less than 50 feet per roll, see Note, item 151781, etc...☒Cancel; see item 150550.	
151781-A	NOTE—☒Cancel; no further application.	
151800-A	Wrapping , NOI, other than corrugated, fluted or indented, etc...☒Cancel; see item 150550.	
151820-A	Writing , folded, see Note, item 151822, etc...☒Cancel; see item 150550.	
151822-A	NOTE—☒Cancel; no further application.	
	PAPER ARTICLES GROUP: subject to item 152000	
153120-A	File Folders , paper or pulpboard, folded, etc...☒Cancel; see item 179180.	
153730-A	Pads , desk blotter, pulpboard, with blotter retainers of fabric, paper or pulpboard, etc...☒Cancel; see item 179180.	

ITEM	ARTICLE	CLASS
<p>▶156600-B</p> <p>Sub 1</p> <p>Sub 2</p> <p>Sub 3</p> <p>Sub 4</p> <p>Sub 5</p> <p>Sub 6</p> <p>Sub 7</p> <p>Sub 8</p> <p>Sub 9</p> <p>Sub 10</p> <p>Sub 11</p>	<p>PLASTIC OR RUBBER ARTICLES GROUP: subject to item 156500</p> <p>Articles, see Note, item 156601, viz.:</p> <p>Articles, NOI;</p> <p>Bands, elastic, including Rubber Bands;</p> <p>Baskets, Holders or Filters, coffee, automatic coffee maker, plastic and cloth combined;</p> <p>Bobbins; Cores, winding or filter; Cop Tubes; Dye Tubes; Pirns; Reels, NOI; or Spools;</p> <p>Car Seats, child or baby;</p> <p>Columns; or other Forms or Shapes, NOI; architectural;</p> <p>Containers, packaging, NOI;</p> <p>Dinnerware or Tableware, NOI;</p> <p>Faucets, NOI, or Bibcocks;</p> <p>Film or Sheeting, foam, cellular, expanded or sponge plastic or rubber, NOI;</p> <p>Garbage, Waste, Refuse or Recycling Cans or Containers;</p> <p>Gloves, see Note, item 156604;</p> <p>Grips, NOI, including Golf Club, Hand Tool or Handlebar Grips;</p> <p>Liners, swimming pool, plastic film or sheeting;</p> <p>Materials, Forms or Shapes, foam, cellular, expanded or sponge plastic or rubber, NOI;</p> <p>Mats, bathtub, shower stall, drainboard, sink or stove protector;</p> <p>Molding, facing, baseboard or cove, foam, cellular, expanded or sponge plastic or rubber, including Ceiling Medallions or Cornices;</p> <p>Molding, other than facing, baseboard or cove;</p> <p>Pipe or Pipe Fittings;</p> <p>Poultry Watering Systems, see Note, item 156603;</p> <p>Straps, Bungee Cord or Shock Cord, lashing, tying or securing, with or without hooks or other fasteners or fittings;</p> <p>Tanks, NOI;</p> <p>Tape, NOI;</p> <p>Tips, crutch or furniture;</p> <p>Tire Patches, Plugs or Liners;</p> <p>Tractor Treads, rubber;</p> <p>Traffic or Road Markers, including Cones, Barrels, Drums or Posts;</p> <p>Tubing, NOI, other than flexible;</p> <p>In boxes, crates, drums or Packages 1078, 1241, 1273 or 2213, see Note, item 156602, subject to Item 170 and having a density in pounds per cubic foot of:</p> <p>Less than 1.....</p> <p>1 but less than 2.....</p> <p>2 but less than 4.....</p> <p>4 but less than 6.....</p> <p>6 but less than 8.....</p> <p>8 but less than 10.....</p> <p>10 but less than 12.....</p> <p>12 but less than 15.....</p> <p>15 but less than 22.5.....</p> <p>22.5 but less than 30.....</p> <p>30 or greater.....</p>	<p></p> <p>400</p> <p>300</p> <p>250</p> <p>175</p> <p>125</p> <p>100</p> <p>92.5</p> <p>85</p> <p>70</p> <p>65</p> <p>60</p>
<p>△156601-A</p>	<p>NOTE—Except as otherwise specified, this item applies on plastic or rubber articles whether or not of foam, cellular, expanded or sponge construction.</p>	
<p>△156602-B</p>	<p>NOTE—The following departures from packing requirements are permitted:</p> <ol style="list-style-type: none"> 1. Necks of empty carboys may project from boxes or crates. 2. Rigid plastic pipe or tubing, or tubes other than containers, may be shipped in packages with threaded or belled ends protected. 3. Flexible plastic pipe or tubing, or tubes other than containers, may be shipped in coils with threaded or belled ends protected, or on reels. 4. Plastic pipe fittings may be shipped in packages with threaded or belled ends protected. 5. Flexible plastic fencing or mesh, produced by a stretching and extruding process, may be shipped in bundles or rolls. 6. Swimming pool and pond liners may be shipped in bundles or rolls. 7. Plastic plate or sheet with formed interior cells, cavities or flutes may be shipped securely fastened to lift truck skids, pallets or platforms and must not overhang the edges of the lift truck skid, pallet or platform deck. Exposed surfaces and edges must be completely wrapped with plastic film or corrugated fiberboard or protected by wood or similar material. 8. Cups or tumblers, without handles, may be shipped in Packages 2471 or 2505. 9. Not currently used. 10. The following articles may be shipped in packages: <ol style="list-style-type: none"> a. Garbage, waste, refuse or recycling cans or containers; b. Plastic bottle carrying boxes or crates; c. Plastic tanks, other than outer shipping containers; d. Poultry watering systems. e. Traffic or road markers, including cones, barrels, drums or posts. 	
<p>△156603-B</p>	<p>NOTE—Applies on poultry watering systems consisting of pipe, plastic drinkers, water filtering, metering or regulating devices and equipment necessary for installation, with or without other components or accessories.</p>	
<p>△156604-B</p>	<p>NOTE—Does not apply on any commodity which is defined and specified as medical waste in Federal regulations. For applicable class, see item 101682.</p>	
<p>160450-A</p>	<p>Polishers, leather or vinyl, consisting of expanded plastic applicator pads or sponges impregnated with polishing, dressing or cleaning compounds, with or without plastic cases or covers, etc...☒Cancel; see item 160460.</p>	

ITEM	ARTICLE	CLASS
<p>★160460</p> <p>Sub 1</p> <p>Sub 2</p> <p>Sub 3</p>	<p>Polish, Polishing Compounds, Polishing Wax and Related Articles, not required by the U.S. Department of Transportation to bear a Hazard Class or Hazard Division label or placard, see Notes, items 160461 and 160462, viz.:</p> <p>Automobile, Boat or Vehicle Polish or Wax; Buffing Compounds, NOI; Cloths, Pads, Sponges or Wipes, treated or impregnated with polish or wax; Floor or Furniture Polish or Wax; Leather Polish, Dressing or Conditioners; Polish, Polishing Compounds or Polishing Wax, NOI; Shoe Polish, Dressing, Cleaners or Wax;</p> <p>In boxes, drums or pails, subject to Item 170 and having a density in pounds per cubic foot of:</p> <p>Less than 12 12 but less than 22.5..... 22.5 or greater</p>	<p>110</p> <p>70</p> <p>65</p>
<p>★160461</p>	<p>NOTE—Also applies on products that clean as well as polish.</p>	
<p>★160462</p>	<p>NOTE—Does not apply on materials regulated by the U.S. Department of Transportation as hazardous and required to bear a Hazard Class or Hazard Division label or placard. For classes applicable to such hazardous materials, see provisions elsewhere in this Classification.</p>	
<p>162910-A</p> <p>▶162920-A</p> <p>Sub 1</p> <p>Sub 2</p> <p>Sub 3</p>	<p>Pumice Stone Bricks or Blocks, scouring or polishing, etc...☒Cancel; see item 162920.</p> <p>Pumice, including Pumice Stone or Lava Rocks, see Note, item 162921, in bags or boxes, subject to Item 170 and having a density in pounds per cubic foot of:</p> <p>Less than 15..... 15 but less than 30..... 30 or greater</p>	<p>100</p> <p>65</p> <p>55</p>
<p>★162921</p>	<p>NOTE—Also applies on Pumice Stone Blocks or Forms.</p>	
<p>△173720-A</p>	<p>SEEDS: subject to item 172750</p>	<p>55</p>
<p>△174002-A</p>	<p>Seed Beans; Seed Corn; Seed Peas, NOI; or Seed Grain, NOI; see Note, item 174002, in bags, boxes or drums... NOTE—Will also apply on seed or soil inoculating bacteria or agricultural insecticides or fungicides, not exceeding 2 percent of the gross weight of the shipment, when in the same shipping container with seeds.</p>	
<p>174610-A</p> <p>Sub 1</p> <p>Sub 2</p> <p>Sub 3</p> <p>Sub 4</p> <p>Sub 5</p> <p>Sub 6</p> <p>Sub 7</p> <p>Sub 8</p> <p>Sub 9</p> <p>Sub 10</p> <p>Sub 11</p>	<p>SHEET STEEL ARTICLES GROUP: subject to item 174300</p> <p>Containers, viz.:</p> <p>Barrels, Drums or Kegs, NOI, shipping, see Note, item 174611; Boxes, NOI; ▶Cans, Containers, Dispensers or Tanks, fuel or flammable liquid storage or dispensing, hand portable, with or without components of other materials; Cans, NOI, see Note, item 174612; Pails or Buckets, NOI; ▶In packages, subject to Item 170 and having a density in pounds per cubic foot of:</p> <p>Less than 1..... 1 but less than 2..... 2 but less than 4..... 4 but less than 6..... 6 but less than 8..... 8 but less than 10..... 10 but less than 12..... 12 but less than 15..... 15 but less than 22.5..... 22.5 but less than 30..... 30 or greater.....</p>	<p>400</p> <p>300</p> <p>250</p> <p>175</p> <p>125</p> <p>100</p> <p>92.5</p> <p>85</p> <p>70</p> <p>65</p> <p>60</p>
<p>△174611-A</p>	<p>NOTE—Also applies when containers are equipped with plastic inserts or liners.</p>	
<p>△174612-A</p>	<p>NOTE—Also applies when one or both ends are made of aluminum.</p>	
<p>174613-A</p>	<p>NOTE—☒Cancel; no further application.</p>	
<p>178080-A</p>	<p>Sprinkler Heads, automatic fire extinguisher, etc...☒Cancel; see item 178090.</p>	
<p>178090-A</p> <p>Sub 1</p> <p>Sub 2</p> <p>Sub 3</p> <p>Sub 4</p> <p>Sub 5</p> <p>Sub 6</p> <p>Sub 7</p> <p>Sub 8</p> <p>Sub 9</p> <p>Sub 10</p> <p>Sub 11</p>	<p>Sprinklers, ▶Sprinkler Heads or Sprinkler Systems, see Note, item 178091, in boxes, subject to Item 170 and having a density in pounds per cubic foot of:</p> <p>Less than 1..... 1 but less than 2..... 2 but less than 4..... 4 but less than 6..... 6 but less than 8..... 8 but less than 10..... 10 but less than 12..... 12 but less than 15..... 15 but less than 22.5..... 22.5 but less than 30..... 30 or greater.....</p>	<p>400</p> <p>300</p> <p>250</p> <p>175</p> <p>125</p> <p>100</p> <p>92.5</p> <p>85</p> <p>70</p> <p>65</p> <p>60</p>
<p>★178091</p>	<p>NOTE—Applies on sprinkler systems consisting of plastic or rubber hose or tubing with fittings and sprinkler heads.</p>	
<p>178095-A</p>	<p>Sprinkler Heads, pulsating, metal, etc...☒Cancel; see item 178090.</p>	
<p>178850-A</p>	<p>STATIONERY GROUP:...☒Cancel; no further application.</p>	
<p>178910-A</p>	<p>Calendars and Related Articles, etc...☒Cancel; see item 179180.</p>	
<p>178911-A</p>	<p>NOTE—☒Cancel; no further application.</p>	
<p>178920-A</p>	<p>Chalk, school or marking, other than pastels, etc...☒Cancel; see item 179180.</p>	
<p>178930-A</p>	<p>Crayons, school or marking, other than artists', see Note, item 178931, etc...☒Cancel; see item 179180.</p>	

ITEM	ARTICLE	CLASS
	STATIONERY GROUP: subject to item 178850	
178931-A	NOTE—☒Cancel; no further application.	
178970-A	Desk Pen Sets (Pens and Inkwells or Bases), etc...☒Cancel; see item 179180.	
178980-A	Dispensers or Holders, tape, NOI, etc...☒Cancel; see item 179180.	
178990-A	Erasers, NOI, etc...☒Cancel; see item 179180.	
178995-A	Erasers, rubber or rubber compound combined or not combined with other materials; or Eraser Stock, rubber or rubber compound, viz.: Blocks, Plugs, Rods, Sticks or Strips, etc...☒Cancel; see item 179180.	
179020-A	Inkstands or Inkwells, etc...☒Cancel; see item 179180.	
179050-A	Lead Pencils, wooden, other than mechanical or ball point, etc...☒Cancel; see item 179180.	
179055-A	Lifters or Protectors, loose-leaf binder sheet, etc...☒Cancel; see item 179180.	
179057-A	Markers, bingo game, consisting of plastic bottles containing not less than 1½ ounces of ink with integral sponge applicator, etc...☒Cancel; see item 179180.	
179065-A	Pads, inking, etc...☒Cancel; see item 179180.	
179070-A	Pads, memorandum, desk, with metal or plastic holders, see Note, item 179072, etc...☒Cancel; see item 179180.	
179072-A	NOTE—☒Cancel; no further application.	
179090-A	Paperweights, etc...☒Cancel; see item 179180.	
179100-A	Parchment or Vellum, etc...☒Cancel; see item 150550 and provisions otherwise applicable.	
179120-A	Pen Holders, Pen Holder Sticks, Slate Pencils, Paper Wrapped Pencils, Mechanical Crayon Markers, or Children's School Pencil or Pen Holder Sets, etc...☒Cancel; see item 179180.	
179140-A	Pen Points, steel, etc...☒Cancel; see item 179180.	
179150-A	Ribbon, Paper or Tape, carbonized or inked for magnetic printing, etc...☒Cancel; see item 179180.	
179160-A	Ribbons, inked, etc...☒Cancel; see item 179180.	
179175-A	Sheets, memorandum, paper, in plastic holders, etc...☒Cancel; see item 179180.	
▶179180-A	<p>Stationery or Office Supplies, viz.:</p> <p>Binders or Covers, book or loose-leaf, NOI, with or without binding mechanism;</p> <p>Calendars, Agenda Books, Appointment Books or Day Planners, NOI;</p> <p>Clipboards, including Storage Clipboards;</p> <p>Desk Accessories, NOI, including Pen or Pencil Sets, Tape Dispensers or Holders, Desk or Letter Trays, Desk Blotters or Desk Pads, or Paperweights;</p> <p>Erasers, NOI;</p> <p>Fasteners, Clips, Clasps or Holders, paper or letter file;</p> <p>File Folders, Pockets or Jackets, NOI;</p> <p>Ink or Stamping Pads;</p> <p>Lifters or Protectors, loose-leaf;</p> <p>Pencils, Pens, Markers, Crayons or Chalk, writing, marking or drawing, NOI;</p> <p>Ribbons, inked, NOI;</p> <p>Stationery, NOI;</p> <p>Stationery Sets or Papeteries, see Note, item 179182;</p> <p>Stencils, NOI;</p> <p>Thumbtacks or Push Pins;</p> <p style="padding-left: 20px;">In boxes, subject to Item 170 and having a density in pounds per cubic foot of:</p>	
Sub 1	Less than 1	400
Sub 2	1 but less than 2	300
Sub 3	2 but less than 4	250
Sub 4	4 but less than 6	175
Sub 5	6 but less than 8	125
Sub 6	8 but less than 10	100
Sub 7	10 but less than 12	92.5
Sub 8	12 but less than 15	85
Sub 9	15 but less than 22.5	70
Sub 10	22.5 but less than 30	65
Sub 11	30 or greater	60
△179182-A	NOTE—Applies on sets of writing paper, note cards or paper, greeting cards or envelopes, with or without complement of accessories, such as albums, address books, journals, rubber stamps, stickers, pens or pencils in same retail package.	
179200-A	Thumbtacks, etc...☒Cancel; see item 179180.	
△181920-A	<p>Targets, NOI, including Military Targets, in boxes or crates, see Note, item 181921, subject to Item 170 and having a density in pounds per cubic foot of:</p>	
Sub 1	Less than 1	400
Sub 2	1 but less than 2	300
Sub 3	2 but less than 4	250
Sub 4	4 but less than 6	175
Sub 5	6 but less than 8	125
Sub 6	8 but less than 10	100
Sub 7	10 but less than 12	92.5
Sub 8	12 but less than 15	85
Sub 9	15 but less than 22.5	70
Sub 10	22.5 but less than 30	65
Sub 11	30 or greater	60
△181921-A	NOTE—Military aerial tow-type targets may be shipped in Package 2084.	

ITEM	ARTICLE	CLASS																																	
187645-A	<p>TRUNKS, TRAVELING BAGS OR RELATED ARTICLES: subject to item 187600</p> <p>Carrying Cases or Bags, viz.: Air Transport of America (ATA) Cases; Archery Bow Cases; Audio (Sound) Recording Carrying Cases; Backpack or Front-pack Baby Carriers, including Slings or Wraps; Backpacks; Bowling Ball or Bowling Shoe Bags or Cases; Boxes or Bags, lunch or picnic, NOI, with or without food or beverage containers; Camera, Camera Equipment or Film Projector Carrying Bags, Cases or Pouches; Carrying Cases or Bags, NOI; Duffel or Barracks Bags; Footlockers; ►Golf Bags; Gun Carrying Cases; Handbags; Hatboxes; Haversacks; Knapsacks; Luggage, NOI; Musical Instrument Cases, NOI; Pack Carriers, NOI; Pocketbooks or Purses; Sample Cases; Suitcases; Traveling Bags; Trunks;</p> <p>In boxes, crates or Package 2213, see Note, item 187682, subject to Item 170 and having a density in pounds per cubic foot of:</p> <table border="0"> <tr> <td>Sub 1</td> <td>Less than 1.....</td> <td>400</td> </tr> <tr> <td>Sub 2</td> <td>1 but less than 2.....</td> <td>300</td> </tr> <tr> <td>Sub 3</td> <td>2 but less than 4.....</td> <td>250</td> </tr> <tr> <td>Sub 4</td> <td>4 but less than 6.....</td> <td>175</td> </tr> <tr> <td>Sub 5</td> <td>6 but less than 8.....</td> <td>125</td> </tr> <tr> <td>Sub 6</td> <td>8 but less than 10.....</td> <td>100</td> </tr> <tr> <td>Sub 7</td> <td>10 but less than 12.....</td> <td>92.5</td> </tr> <tr> <td>Sub 8</td> <td>12 but less than 15.....</td> <td>85</td> </tr> <tr> <td>Sub 9</td> <td>15 but less than 22.5.....</td> <td>70</td> </tr> <tr> <td>Sub 10</td> <td>22.5 but less than 30.....</td> <td>65</td> </tr> <tr> <td>Sub 11</td> <td>30 or greater.....</td> <td>60</td> </tr> </table>	Sub 1	Less than 1.....	400	Sub 2	1 but less than 2.....	300	Sub 3	2 but less than 4.....	250	Sub 4	4 but less than 6.....	175	Sub 5	6 but less than 8.....	125	Sub 6	8 but less than 10.....	100	Sub 7	10 but less than 12.....	92.5	Sub 8	12 but less than 15.....	85	Sub 9	15 but less than 22.5.....	70	Sub 10	22.5 but less than 30.....	65	Sub 11	30 or greater.....	60	
Sub 1	Less than 1.....	400																																	
Sub 2	1 but less than 2.....	300																																	
Sub 3	2 but less than 4.....	250																																	
Sub 4	4 but less than 6.....	175																																	
Sub 5	6 but less than 8.....	125																																	
Sub 6	8 but less than 10.....	100																																	
Sub 7	10 but less than 12.....	92.5																																	
Sub 8	12 but less than 15.....	85																																	
Sub 9	15 but less than 22.5.....	70																																	
Sub 10	22.5 but less than 30.....	65																																	
Sub 11	30 or greater.....	60																																	
△187682-A	<p>NOTE—Will not apply on articles of plastic film or sheeting construction having an overall thickness of 1/8 inch or less exclusive of handles or closing devices. For classes on these articles, see item 20480.</p>																																		
196640-A	<p>WAX: subject to item 196560</p> <p>Carnauba, etc... ☒Cancel; see items 160460 and 196880.</p>																																		
196840-A	<p>Shoe or Harness Makers', etc... ☒Cancel; see item 160460.</p>																																		
△196880-A	<p>Wax, NOI, in bags, boxes or drums.....</p>	100																																	

SPECIFICATIONS FOR NUMBERED PACKAGES

Package 942	<input checked="" type="checkbox"/> Cancel; no further application.
Package 2174	<input checked="" type="checkbox"/> Cancel; no further application.
Package 2400	<input checked="" type="checkbox"/> Cancel; no further application.
Package 2488	<input checked="" type="checkbox"/> Cancel; no further application.
Package 2491	<input checked="" type="checkbox"/> Cancel; no further application.
Package 6F	<input checked="" type="checkbox"/> Cancel; obsolete.
Package 7F	<input checked="" type="checkbox"/> Cancel; obsolete.
Package 8F	<input checked="" type="checkbox"/> Cancel; obsolete.
Package 9F	<input checked="" type="checkbox"/> Cancel; obsolete.
Package 15F	<input checked="" type="checkbox"/> Cancel; obsolete.
Package 16F	<input checked="" type="checkbox"/> Cancel; obsolete.
Package 23F	<input checked="" type="checkbox"/> Cancel; obsolete.
Package 24F	<input checked="" type="checkbox"/> Cancel; obsolete.
Package 31F	<input checked="" type="checkbox"/> Cancel; obsolete.
Package 34F	<input checked="" type="checkbox"/> Cancel; obsolete.
Package 38F	<input checked="" type="checkbox"/> Cancel; obsolete.

SPECIFICATIONS FOR NUMBERED PACKAGES

Package 39F

Cancel; obsolete.

Package 40F

Cancel; obsolete.

Package 41F

Cancel; obsolete.

Package 43F

Cancel; obsolete.

Package 45F

Cancel; obsolete.

Package 46F

Cancel; obsolete.

Package 50F

Cancel; obsolete.

Package 52F

Cancel; obsolete.

Package 53F

Cancel; obsolete.

Package 61F

Cancel; obsolete.

Package 64F

Cancel; obsolete.

Package 67F

Cancel; obsolete.

Package 69F

Cancel; obsolete.

Package 72F

Cancel; obsolete.

Package 77F

Cancel; obsolete.

Package 79F

Cancel; obsolete.

SPECIFICATIONS FOR NUMBERED PACKAGES

<input checked="" type="checkbox"/> Cancel; obsolete.	Package 80F
<input checked="" type="checkbox"/> Cancel; obsolete.	Package 85F
<input checked="" type="checkbox"/> Cancel; obsolete.	Package 86F
<input checked="" type="checkbox"/> Cancel; obsolete.	Package 87F
<input checked="" type="checkbox"/> Cancel; obsolete.	Package 88F
<input checked="" type="checkbox"/> Cancel; obsolete.	Package 91F
<input checked="" type="checkbox"/> Cancel; obsolete.	Package 92F
<input checked="" type="checkbox"/> Cancel; obsolete.	Package 93F
<input checked="" type="checkbox"/> Cancel; obsolete.	Package 95F
<input checked="" type="checkbox"/> Cancel; obsolete.	Package 97F
<input checked="" type="checkbox"/> Cancel; obsolete.	Package 98F
<input checked="" type="checkbox"/> Cancel; obsolete.	Package 101F
<input checked="" type="checkbox"/> Cancel; obsolete.	Package 106F
<input checked="" type="checkbox"/> Cancel; obsolete.	Package 109F
<input checked="" type="checkbox"/> Cancel; obsolete.	Package 110F
<input checked="" type="checkbox"/> Cancel; obsolete.	Package 111F

SPECIFICATIONS FOR NUMBERED PACKAGES

Package 114F

Cancel; obsolete.

Package 115F

Cancel; obsolete.

Package 117F

Cancel; obsolete.

Package 125F

Cancel; obsolete.

Package 126F

Cancel; obsolete.

Package 127F

Cancel; obsolete.

Package 128F

Cancel; obsolete.

Package 129F

Cancel; obsolete.

Package 131F

Cancel; obsolete.

Package 132F

Cancel; obsolete.

Package 133F

Cancel; obsolete.

Package 134F

Cancel; obsolete.

Package 135F

Cancel; obsolete.

Package 136F

Cancel; obsolete.

Package 138F

Cancel; obsolete.

Package 139F

Cancel; obsolete.

SPECIFICATIONS FOR NUMBERED PACKAGES

<input checked="" type="checkbox"/> Cancel; obsolete.	Package 140F
<input checked="" type="checkbox"/> Cancel; obsolete.	Package 141F
<input checked="" type="checkbox"/> Cancel; obsolete.	Package 142F
<input checked="" type="checkbox"/> Cancel; obsolete.	Package 144F
<input checked="" type="checkbox"/> Cancel; obsolete.	Package 145F
<input checked="" type="checkbox"/> Cancel; obsolete.	Package 146F
<input checked="" type="checkbox"/> Cancel; obsolete.	Package 149F
<input checked="" type="checkbox"/> Cancel; obsolete.	Package 150F
<input checked="" type="checkbox"/> Cancel; obsolete.	Package 152F
<input checked="" type="checkbox"/> Cancel; obsolete.	Package 155F
<input checked="" type="checkbox"/> Cancel; obsolete.	Package 156F
<input checked="" type="checkbox"/> Cancel; obsolete.	Package 3000S
<input checked="" type="checkbox"/> Cancel; obsolete.	Package 3001S
<input checked="" type="checkbox"/> Cancel; obsolete.	Package 3002S
<input checked="" type="checkbox"/> Cancel; obsolete.	Package 3003S
<input checked="" type="checkbox"/> Cancel; obsolete.	Package 3004S

SPECIFICATIONS FOR NUMBERED PACKAGES

Package 3005S

Cancel; obsolete.

Package 3006S

Cancel; obsolete.

Package 3007S

Cancel; obsolete.

Package 3008S

Cancel; obsolete.

Package 3009S

Cancel; obsolete.

Package 3010S

Cancel; obsolete.

PROCEDURES GOVERNING THE INVESTIGATION AND DISPOSITION OF FREIGHT CLAIMS FOR LOSS OR DAMAGE

ITEM 300105-A

FILING OF CLAIMS

(a) Compliance with Regulations. ►A claim for loss or damage to cargo will not be voluntarily paid by a carrier unless the freight charges for the involved cargo have been paid in full and the minimum filing requirements set forth in subsection (b) below have been satisfied. The claim may be filed with the receiving or delivering carrier, or carrier issuing the bill of lading, or carrier on whose line the alleged loss or damage occurred, within the specified time limits applicable thereto and as otherwise may be required by law, the terms of the bill of lading or other contract of carriage, and all tariff provisions applicable thereto.

(b) Minimum Filing Requirements. A written or electronic communication from a claimant, filed with a proper carrier within not more than nine (9) months from the date of delivery in the event of a damage claim, and not more than nine (9) months from the date of the bill of lading in the event of loss, at a minimum shall be accompanied by the following documents and/or information:

1. A copy of the bill of lading or facts sufficient to enable the carrier to whom the notice of the claim is submitted to identify the shipment(s) of property alleged to have been lost or damaged,
2. Facts and documents upon which the claimant's assertion of carrier liability for the alleged damage or loss is based,
3. A specified or determinable amount of money for the alleged damage or loss, and the documents and/or information establishing the basis for that amount of money.

(c) Actual Loss or Damage. Unless a reduced valuation is established or agreed to by the carrier for the commodity shipped, carrier liability, as set forth in Section 14706(a) of 49 U.S.C., shall be for the actual loss or damage to the property. Actual loss or damage to the property is based on each article, package or piece shipped. Whether one or more articles, packages or pieces of property are tendered individually or secured or unitized for shipment, carrier liability will be determined based on the weight of each individual article, package or piece lost or damaged, and not on the total weight of the handling unit or shipment. The term 'package' means any shipping container authorized by the provisions of the National Motor Freight Classification, or those permitted in the individual carrier's tariff, applicable on the involved articles on the date of shipment.

(d) Documents Not Constituting Claims. Appraisal reports of damage, notations of shortage or damage, or both, on freight bills, delivery receipts, or other documents, or inspection reports issued by carriers or their inspection agencies, whether the extent of loss or damage is indicated in dollars and cents or otherwise, shall, standing alone, not be considered by carriers as sufficient to comply with the minimum claim filing requirements specified in paragraph (b) of this section.

(e) Claims Filed for Uncertain Amounts. ►Whenever a claim is presented against an identified carrier for an uncertain amount, the carrier against whom such claim is filed shall determine the condition of the shipment involved at the time of delivery by it, if it was delivered, and shall ascertain as nearly as possible the extent, if any, of the loss or damage for which it may be responsible. It shall not, however, voluntarily pay a claim under such circumstances unless and until a claim for a specified or determinable amount of money shall have been filed in accordance with the provisions of paragraph (b) of this section.

(f) Other Claims. If investigation of a claim develops that one or more other carriers has been presented with a similar claim on the same shipment, the carrier investigating such claim shall communicate with each such other carrier and, prior to any agreement entered into between or among them as to the proper disposition of such claim or claims, shall notify all claimants of the receipt of conflicting or overlapping claims and shall require further substantiation on the part of each claimant of their title to the property involved or their right with respect to such claim.

(g) Delivery Receipt.

1. A shipping container(s) or package(s) showing any external signs of damage when received by the consignee is to be noted on the delivery receipt and such shipping container or package is to be opened promptly and the contents inspected by the consignee.

2. Possession of a signed delivery receipt ►(see Item 500300), with no exceptions or damage noted thereon, shall be prima facie evidence that the carrier has successfully discharged its obligations under Section 14706 of 49 U.S.C.

►3. If a consignee is absent or does not sign the delivery receipt, carrier may use any internal records, such as GPS coordinates, photographs, drivers' logs or some combination thereof or the like, as evidence or proof of delivery. Such proof of delivery with no exceptions taken shall result in carrier being absolved of any cargo claims for the shipments tendered to the consignee.

(h) Civil Action. A civil action must be filed not more than two (2) years from the date on which the carrier provided written or electronic notice disallowing all or part of the claim.

ITEM 300115-A

INVESTIGATION OF CLAIMS

(a) Prompt Investigation Required. Each claim filed against a carrier in the manner prescribed in these procedures shall be promptly and thoroughly investigated if investigation has not already been made prior to receipt of the claim.

(b) Supporting Documents. When a necessary part of an investigation, each claim shall be supported by the original bill of lading, evidence of the freight charges, if any, and either the original invoice, a photographic copy of the original invoice, or a ►notarized exact copy thereof or any extract made therefrom, certified by the claimant to be true and correct with respect to the property and value involved in the claim; or when those documents are not available, a ►notarized certification of prices or values, with trade or other discounts, allowance, or deductions, of any nature whatsoever and the terms thereof, or depreciation reflected thereon; Provided, however, that where property involved in a claim has not been invoiced to the consignee shown on the bill of lading or where an invoice does not show price or value, or where the property involved has been sold, or where the property has been transferred at bookkeeping values only, the carrier shall, before voluntarily paying a claim, require the claimant to establish the destination value in the quantity, shipped, transported, or involved; Provided, further, that when supporting documents are determined to be a necessary part of an investigation, the supporting documents are retained by the carriers for possible FMCSA inspection.

(c) Verification of Loss. When an asserted claim for loss of an entire package or an entire shipment cannot be otherwise authenticated upon investigation, the carrier shall obtain from the consignee of the shipment involved a certified statement in writing or electronically that the property for which the claim is filed has not been received from any other source.

PROCEDURES GOVERNING THE INVESTIGATION AND DISPOSITION OF FREIGHT CLAIMS FOR LOSS OR DAMAGE

▶ITEM 300125-A

RETENTION AND PROCESSING OF SALVAGE

(a) When visible or open damage to a shipment has been established by notation having been given at time of delivery or concealed damage established by inspection report, it is the duty of the consignee to retain damaged merchandise and shipping container until carrier desires to take possession of merchandise as salvage. If record conclusively reflects carrier liability, carrier will take possession of the damaged merchandise within 30 days from date shipment was noted damaged on carrier delivery receipt or from date of inspection report, if damage was concealed. If carrier does not take possession of the damaged merchandise within the time prescribed above, consignee must contact delivering carrier in writing or electronically and request removal of goods from their premises within 15 days from the date of such communication. The above applies only when the carrier and consignee agree that the carrier will handle disposition of the salvage, and does not in any manner affect the legal duty that the consignee, when there is substantial value in the salvage, must accept and handle it in such a manner as to mitigate the carrier's loss as much as possible. If there is doubt of carrier liability, the carrier will so advise consignee; in which event the consignee may hold the merchandise until liability of carrier is determined, or may dispose of it so as to mitigate the damage, and may file claim for such damage. Carrier will remove the damaged goods within the 15-day period or advise consignee that carrier liability is in doubt and that damaged merchandise is to be retained by the consignee until carrier has completed investigation of claim.

(b) Whenever material, goods or other property transported by a carrier subject to the provisions herein is damaged or alleged to be damaged and is, as a consequence thereof, not delivered, or is rejected or refused upon tender thereof to the owner, consignee, or person entitled to receive such property, the carrier, after giving due notice, whenever practicable to do so, to the owner and other parties that may have an interest therein, and unless advised to the contrary after giving such notice, shall undertake to sell or dispose of such property directly or by the employment of a competent salvage agent. The carrier shall only dispose of the property in a manner that will fairly and equally protect the best interests of all persons having an interest therein. The carrier shall make an itemized record sufficient to identify the property involved so as to be able to correlate it to the shipment or transportation involved, and claim, if any, filed thereon. The carrier also shall assign to each lot of such property a successive lot number and note that lot number on its record of shipment and claim, if any claim is filed thereon.

(c) Whenever disposition of salvage material or goods shall be made directly to an agent or employee of a carrier or through a salvage agent or company in which the carrier or one of its directors, officers, or managers has any interest, financial or otherwise, that carrier's salvage records shall fully reflect the particulars of each such transaction or relationship, or both, as the case may be.

(d) Upon receipt of a claim number on a shipment on which salvage has been processed in the manner herein before prescribed, the carrier shall record in its claim file thereon the lot number assigned, the amount of money recovered, if any, from the disposition of such property, and the date of transmittal of money to the person or persons lawfully entitled to receive the same.

ITEM 300130-A

PILFERAGE

Cancel; no further application.

▶ITEM 300135-A

REPORTING CONCEALED DAMAGE

(a) When damage to, or loss of, contents of a shipping container is discovered by the consignee that could not have been determined at time of delivery it must be reported by the consignee to the delivering carrier upon discovery.

(b) Reports must include a request for inspection by the carrier's representative.

(c) Notice of loss or damage and request for inspection may be given by telephone or in person, but in either event must be confirmed by a written or electronic communication.

(d) While awaiting inspection by carrier, the consignee must hold the shipping container and its contents in the same condition they were in when damage was discovered, insofar as it is possible to do so.

(e) Unless otherwise specified by the carrier, notice of loss or damage should be provided to the carrier within five (5) business days from the date of delivery.

(f) If five (5) business days, or such other period as specified by the carrier, pass between the date of delivery of the shipment by carrier and date of report of loss or damage and request for inspection by consignee, it is incumbent upon the consignee to offer reasonable evidence to the carrier's representative when inspection is made that loss or damage was not incurred by the consignee after delivery of shipment by carrier.

(g) Reasonable evidence includes, but is not limited to:

1. Identifying the party(ies) responsible for unloading,
2. Identifying the chain of custody of the article, including prior transportation by any mode,
3. Location(s) of the article(s) once the shipment was received until the damage was noted,
4. Any mechanical or physical handling by the consignee subsequent to delivery by the carrier.

(h) If a concealed damage inspection report covers merchandise which has had prior transportation movement, consignee is required to assist carrier in determining if shipment was opened and inspected by shipper prior to reshipment, and if not, shall then assist carrier in every way possible to establish record of prior transportation.

(i) If a clear delivery receipt is available on the shipment, e.g. no damage or shortage is noted, the claimant must provide documentation showing that damage or loss occurred prior to delivery.

ITEM 300150-A

SALVAGE RETENTION

Cancel; see Item 300125.

ITEM 300155-A

PRIOR TRANSPORTATION

Cancel; see Item 300135.

CARRIER BEST PRACTICES

★ITEM 500300

DEFINITION OF A DELIVERY RECEIPT

A delivery receipt serves as an acknowledgement of delivery of goods to a consignee by a carrier and may be signed by the consignee manually or electronically.

EXPLANATION OF ABBREVIATIONS AND REFERENCE MARKS

Abbreviation or Reference Mark	Explanation	Abbreviation or Reference Mark	Explanation
ASTM	ASTM International	Sec.	Section
Avdp.	Avoirdupois	sq.	square
°C	degree Centigrade (Celsius)	sq. ft.	square foot; square feet
CFR	Code of Federal Regulations	sq. in.	square inch(es)
cm	centimeter(s)	STB	Surface Transportation Board
COD	Collect on Delivery	SU	Set Up
Cont'd	Continued	t/a	trading as
cu	cubic	t/d/b/a	trading and doing business as
cu. ft.	cubic foot; cubic feet	™	Trademark
DOT	Department of Transportation	UN	United Nations
d/b/a	doing business as	U.S.	United States
etc.	et cetera (and other things, or the rest; and so forth)	USC	United States Code
°F	degree Fahrenheit	viz.	namely
g	gram	vol.	volume
gal	gallon(s)	vs.	versus
in.	inch(es)	&	and
incl.	inclusive	°	degree
ISTA	International Safe Transit Association	%	percent
KD	Knocked Down	§	Section
kg	kilogram	☠	Indicates commodity or commodities may be subject to special federal regulations concerning the shipping of hazardous materials. See Item (Rule) 540 herein.
kPa	Kilopascal	▶	Indicates change
L	liter	☒	Indicates cancelation of item or package
lbs.	pounds	△	Indicates that the item is being brought forward without change
m	meter(s)	★	Indicates new item, package or participating carrier
ml	milliliter(s)	Ⓐ	Addition to Index to Articles
mm	millimeter(s)	Ⓑ	Eliminate from Index to Articles
MPa	Megapascal	Ⓒ	Change in Index to Articles
NMFC	National Motor Freight Classification	Ⓔ	These provisions are subject to the expiration date as shown in Item (Rule) 535.
NMFTA	National Motor Freight Traffic Association, Inc.	①	The participation of this carrier is CANCELED; provisions of this Classification no longer apply for account of this carrier.
NOI	Not more specifically described herein	Ⓟ	Under postponement
o/a	operating as	®	Registered trade name or registered trademark
oz.	ounce(s)	⊕	Effective July 6, 2023, under authority of 49 CFR §1312.6(b)(3).
pcf	pounds per cubic foot	●	Indicates correction of printing error
psi	pounds per square inch		
qt.	quart		
RSorL	Classed the same or lower		
r.p.m.	revolutions per minute		
SCAC	Standard Carrier Alpha Code — The SCAC (alpha code) listings in this Classification represent only those carriers participating in the NMFC. For a complete listing of all assigned alpha codes, see the Directory of Standard Carrier Alpha Codes, NMF 101.		

—finis—